



**Operator's Manual  
Electric Jack  
with Automatic Leveling  
Touchpad #140-1226  
Control Box #140-1224  
"Revision OK"**

© Copyright PowerGear 12/07 #82-L0368 Rev. 0D

## Contents

Before You Level Your Coach	1
Caution	1
Leveling System Operating Instructions --	
Buttons and Operation	2
Lights & Function Indicators	2
Selecting A Site	2
Automatic Leveling	2
Manual Leveling	3
Error Codes	3
Error Mode	4
Preventive Maintenance	4
Drive Away Protection	4
Warranty	4



Your coach should be supported at both front and rear axles with jack stands before working underneath, failure to do so may result in personal injury or death.

To prevent movement, use wheel chocks.

Do not use the Power Gear Leveling system (or air suspension) to support the vehicle while changing tires or under the coach for any reason. The leveling system is designed as a "leveling" system only. Tire repairs should only be done by trained professionals. Attempts to change tires while supporting the vehicle with the leveling system could result in damage to your motor home and/or cause serious injury or even death.

Keep people clear of coach while leveling system is in use.

Never lift the wheels off the ground to level the coach. Doing so may create an unstable condition.



1217 E. 7th Street  
Mishawaka, IN 46544  
800/334-4712  
www.powergearus.com

# Operator's Manual

## Automatic Electric Jack Leveling

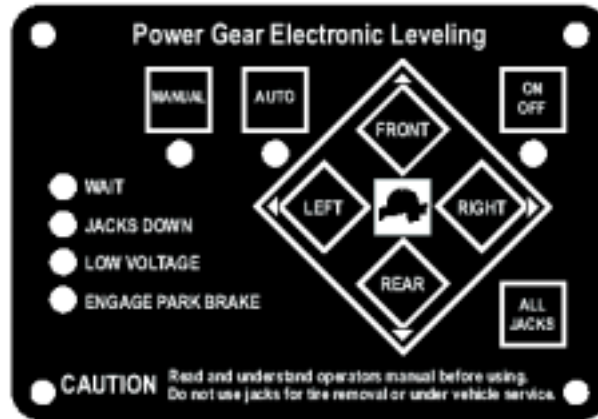

### Before You Operate The System

The leveling system shall only be operated under the following conditions:

1. **Engine is running.**
2. The coach is parked on a reasonably level surface.
3. The coach "PARKING BRAKE" is engaged.
4. The coach transmission should be in the NEUTRAL or PARK position.
5. 13 volts minimum required before system will turn on.
6. Do not extend the slideouts until coach is leveled.



- Park the coach on a reasonably solid surface or the jacks may sink into the ground.
- Check that potential jack contact locations are clear of obstructions or depressions before operation.
- Read and understand the entire operator's manual before using or servicing your leveling system.



Park the coach on a reasonably solid surface or the jacks may sink into ground. On soft surfaces, use load distribution pads under each jack.

Check that potential jack contact locations are clear of obstructions or depressions before operation.



The system will automatically shut down after 5 minutes of inactivity.

Low voltage will prevent the control from operating.

## Leveling System Operating Instructions

### Buttons and Operation

**ON/OFF:** Turns the Touch Pad ON/OFF.

**AUTO:** Initiates an automatic leveling cycle.

**MAN:** Initiates a manual leveling cycle.

**RETRACT ALL JACKS:** In any mode except Manual mode, pressing and releasing "Retract All Jacks" button retracts all the jacks completely. In Manual mode, the jacks will retract only while the "Retract All Jacks" button is held down.

**FRONT/REAR/LEFT/RIGHT:** Extends that pair of jacks while in manual mode.

### LIGHTS AND FUNCTION INDICATORS

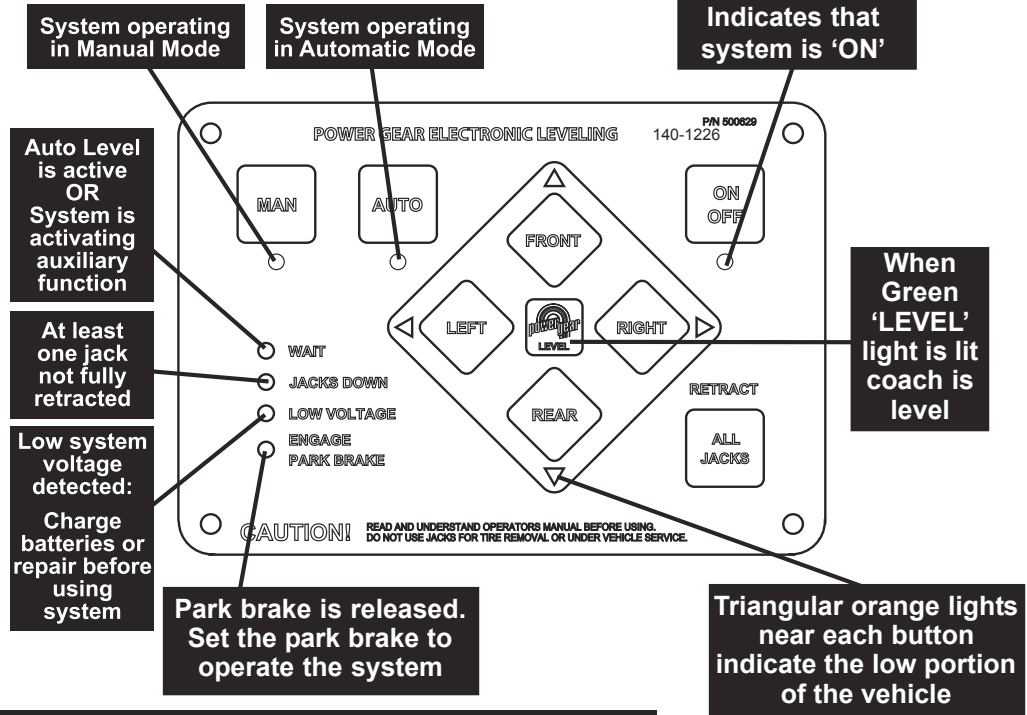

## Selecting A Site

When the coach is parked on an excessive slope, the leveling requirements may exceed the jack lift stroke capability. When this occurs, the 4 orange jack lights and the green "Power Gear Level" light in the center will blink together. The coach must be moved to a more level surface before the leveling jacks are deployed. On the contrary, if the green "Power Gear level" light in the center is on and/or blinking by itself, it means the coach is already level. You may, if you wish, operate the jacks anyway to act as a stabilizer.

## Automatic Leveling

1. Park the coach in a reasonably level area.
2. Put the transmission in "Park" if in a gasoline coach or "Neutral" if in a diesel coach.
3. Set the parking brake.
4. With the **Engine Running**, turn the control on by pressing the touchpad ON/OFF button. There will be a 10 second wait period for the system to stabilize. Verify that all jacks are fully retracted, "Jacks Down" light is not illuminated. (Auto leveling cannot start if the jacks are not fully retracted)
5. Press the AUTO button (Auto light turns on) NOTE: Movements in the vehicle while the system is auto leveling can cause false readings and improper operation. Passengers should remain seated.
6. Jacks will automatically extend to the ground after you press the AUTO button. After the jacks are on the ground, auto leveling begins.
7. The Front/Left/Right/Rear jacks will automatically extend as necessary until the control reaches the pre-programmed level position.
8. The Front/Left/Right/Rear lights show the side or end of the coach being leveled.
9. The Auto light will turn off when the system has been leveled and the center green "Power Gear Level" light will turn on.

### Manual Air Dump Feature

Some diesel models are equipped with a manual air bag dump switch. The air bags should be dumped before attempting to level the coach.

### Jack Retraction While In Auto Mode

To properly retract the jacks, press the "All Jacks" retract button. The jacks will retract to their fully retracted position. The "Jacks Down" light will turn off when all jacks are properly retracted.



### PRODUCT DAMAGE

- Do not move vehicle until levelers are fully retracted ("Jacks Down" light not illuminated).
- Damage can occur to levelers, coach, surrounding property if the levelers are not fully retracted prior to vehicle being moved.

## Manual Leveling

1. Park the coach in a reasonably level area.
2. Put the transmission in "Park" if in a gasoline coach or "Neutral" if in a diesel coach.
3. Set the parking brake.
4. With the **Engine Running**, turn the control on by pressing the touchpad ON/OFF button. There will be a 10 second wait period for the system to stabilize. Verify that all jacks are fully retracted.
5. Press the MAN button (Manual light turns on).
6. If the jacks are fully retracted, the jacks will begin automatically extending. Jacks will stop when the ground is hit. The "Wait" light will blink while the jacks are automatically extending.
7. After the jacks are on the ground, manual features are available.
8. The Front/Left/Right/Rear lights show the side or end of the coach that needs to be extended to reach level. Push and hold the button next to the triangular orange light that is on.
9. Press the manual button when finished with manual mode. Manual light turns back off.

## Manual Override



**Before overriding an electric jack, keep all body parts clear of any**

**pinch points, such as between the wheel well opening and the top of the tire or the bottom of the luggage compartment and the ground. Anytime you are under the coach proper caution must be taken to keep clear of these pinch points. Failure to be aware of this could result in serious injury or death.**

In case of loss of power or communication to the jacks, an Emergency Manual Retract Procedure can be used to retract the jacks. To perform this procedure, **READ ALL STEPS BEFORE ATTEMPTING TO MANUALLY RETRACT THE JACKS.**

1. Turn off the ignition of the vehicle, engage parking brake, put transmission in "Park" for gas chassis applications and in "Neutral" for diesel chassis applications. Reinflate the airbags, if so equipped.
2. Verify that all personnel and tools are clear of the coach. Make sure that all personnel are out of the coach. Retract any slideout room that may be extended.
3. In the event that only communication has been lost with the jack, attempt to manually retract the jack by first applying 12 volts directly to the motor connections.
4. Disconnect the jack motor power plug at the motor. Connect extension power leads to the motor power plug so that the operator can stay out from underneath the coach during manual retract.
5. Apply 12 volts to the extension leads to retract the jack. 12 volt power can be supplied by either the coach or chassis 12 volt batteries. If a battery charger is available, this can be used to supply 12 volts to the leads. Ensure that the jack is retracting after applying power. If the jack is extending, reverse the power extension leads to retract the jack.

## Error Codes

An "Error Code" is indicated by certain lights on the touch pad blinking in a given pattern. Note the pattern indicated below and then find the corresponding mode, which explains the type of error encountered.

BLINKING LIGHT(S) PATTERN	MODE (ERROR)	BLINKING LIGHT(S) PATTERN	MODE (ERROR)
Front, right, rear and left blink in a clockwise pattern	Diagnostic Check (internal - occurs each time system is turned on and will shut off after a few seconds)	Wait	Wait until light turns off
		Low Voltage	Low Input Voltage (check battery)
"Power Gear" logo (green)	Level Achieved	All Lights Blinking & Buzzer	Jacks Down while traveling (jacks not fully retracted, drive-away mode will automatically retract all jacks)
Park Brake	Park Brake not set		All Lights Blinking
Wait & On/Off	Transmission not in park (gas) or neutral (diesel)	Front, right, rear, left & Power Gear logo	Excessive Slope

### Full Extension Protection

If, when operating the control in MANUAL mode, a condition occurs where any one jack of the extending pair reaches full extension, the control will automatically stop the extension of that pair of jacks. Any attempt to further extend that pair will be prevented by the control. The remaining jacks are still operational until they reach full extension.

### Manual Air Dump Feature

Some diesel models are equipped with a manual air bag dump switch. The air bags should be dumped before attempting to level the coach.

### Jack Retraction While In Manual Mode

The "Retract All Jacks" button will manually retract the jacks, but only while the button is held down. Continue to press the ALL JACKS retract button until the "Jacks Down" light turns off, indicating that all jacks have retracted

6. Retract each jack partially until all jacks have cleared the ground, then retract each jack completely.
7. If the motor does not function after applying 12 volts, the jack can be retracted manually using a ratchet, 16mm socket and extension (an electric drill may be used, if available).
8. Remove the rubber boot from the jack motor.
9. Depress the release handle lock and rotate the brake release handle counter-clockwise approximately 10 degrees. See fig.1.
10. Rotate the override nut located on the underside of the jack clockwise (looking from bottom or underneath). See figure 1.
11. Repeat for any other jack not retracted. Retract each jack partially until all jacks have cleared the ground, then retract each jack completely.
12. Make sure that all jacks are in the fully stowed position (jack foot pad all the way up to the bottom of the outside tube of the jack).



**Releasing the brake will result in the jack retracting while under load. The coach may immediately begin to lower. Make certain that you are clear of any pinch points before rotating the brake release handle. Failure to be aware of this condition could result in serious bodily injury or death.**

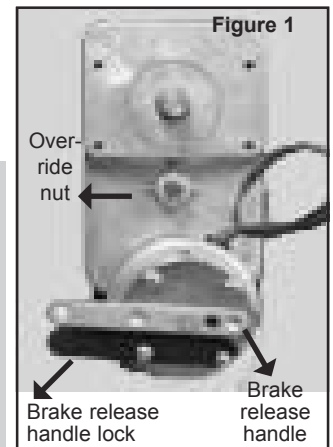

Figure 1

## Error Mode - Troubleshooting

If any problem is detected with the leveling system electronics or motors, the system will enter error mode.

If the AUTO and MAN lights are blinking together, the system is in Error Mode.

- Press the ON/OFF button to disable the buzzer. Make sure the light underneath the ON/OFF button is ON.
- To reset the system, press and hold the ON/OFF button for 3 seconds.
- The Front/Left/Right/Rear lights will tell you which jack is seeing an error. For example, if the Front and Left lights are blinking, the Left Front jack has the error. If the Right and Rear lights are blinking, the Right Rear jack has the error, etc.

When the error is first detected, the buzzer will sound alerting the user of the problem.

There are several things that can cause the control to go into Error Mode:

- Jack motor drawing too much current - short circuit.
- Jack motor drawing too little current-open circuit.
- Jack extending too long-sensor circuit.
- Jack retracting too long-sensor circuit.

If the buzzer continues to sound, the control is in "Emergency

Retract Mode". Verify that the coach is in park (neutral for a diesel engine) and the parking brake is engaged. The light and buzzer

should stop once the jacks are fully retracted.

ALL NORMAL FEATURES ARE DISABLED IN ERROR MODE. The intent of this mode is to allow the user or service technician to individually drive the jacks, in order to isolate the error. Please note that all additional error detection is disabled in this mode.

To assist in identifying and correcting jack problems you can operate the jacks independently while in error mode.

- To operate the left front jack, hold down the Left + Front buttons + "AUTO" to extend, OR "MAN" to retract the jack.
- To operate the right front jack, hold down the Right + Front buttons + "AUTO" to extend, OR "MAN" to retract the jack.
- To operate the left rear jack, hold down the Left + Rear buttons + "AUTO" to extend, OR "MAN" to retract the jack.
- To operate the right rear jack, hold down the Right + Rear buttons + "AUTO" to extend, OR "MAN" to retract the jack.

Once the cause of the error has been eliminated, you can exit error mode by pressing and holding the ON/OFF button for 3 seconds, then to retract the jacks by pressing the ALL JACKS RETRACT button. If all the jacks retract and all lights stop blinking then the system has been successfully reset.

- If the error has been eliminated, the jacks will fully retract and the Touch Pad will return back to normal.
- If the error has not been eliminated, the system will return back to error mode.

## Preventive Maintenance

1. Inspect and clean all electrical connections every 12 months
2. Remove dirt and road debris from jacks as needed.
3. Battery condition is important to the leveling system. Keep batteries fully charged when possible.

## Power Gear Limited Warranty

Power Gear warrants to the original retail purchaser that the product will be free from defects in material and workmanship for a period of (2) years following the retail sales date. Power Gear will, at its option, repair or replace any part covered by this limited warranty, which, following examination by Power Gear or its authorized distributors or dealers, is found to be defective under normal use and service. No claims under this warranty will be valid unless Power Gear or its authorized distributor or dealer is notified in writing of such claim prior to the expiration of the warranty period. Warranty is transferable pending documentation of original sale date of product.

WARRANTY SHALL NOT APPLY TO:

- Failure due to normal wear and tear, accident, misuse, abuse, or negligence.
- Products which are modified or altered in a manner not authorized by Power Gear in writing.
- Failure due to misapplication of product.

## Drive Away Protection

If the ignition is in the "Run" position, the jacks are down, and the operator takes the transmission out of neutral or park, or releases the parking brake, all of the LEDs will flash and the alarm beeper will activate. The system will then automatically retract the jacks until they are fully retracted. During this time the touch pad cannot be turned off.

- Telephone or other communication expenses.
- Living or travel expenses.
- Overtime labor.
- Failures created by improper installation of leveling systems, including final adjustments made at the plant, or low fluid level, wiring or ground problems.
- Replacement of normal maintenance items.

There is no other express warranty other than the foregoing warranty. THERE ARE NO IMPLIED WARRANTIES OF MERCHANTABILITY OR FITNESS FOR A PARTICULAR PURPOSE. IN NO EVENT SHALL POWER GEAR BE LIABLE FOR ANY INCIDENTAL OR CONSEQUENTIAL DAMAGES. This warranty gives you specific legal rights, and you may also have other rights, which vary from state to state. Some states do not allow the limitations of implied warranties, or the exclusion of incidental or consequential damages, so the above limitations and exclusions may not apply to you.

For service contact your nearest Power Gear authorized warranty service facility or call 1-800-334-4712. Warranty service can be performed only by a Power Gear authorized service facility. This warranty will not apply to service at any other facility. At the time of requesting warranty service, evidence of original purchase date must be presented.



1217 E. 7th Street  
Mishawaka, IN 46544  
800/334-4712  
www.powergearus.com

# CAUTION

Park the coach on a reasonably solid surface or the jacks may sink into ground. On soft surfaces, use load distribution pads under each jack.

Check that potential jack contact locations are clear of obstructions or depressions before operation.

# NOTICE

The system will automatically shut down after 5 minutes of inactivity.

Low voltage will prevent the control from operating.

## Leveling System Operating Instructions

### Buttons and Operation

**ON/OFF:** Turns the Touch Pad ON/OFF.

**AUTO:** Initiates an automatic leveling cycle.

**MAN:** Initiates a manual leveling cycle.

**RETRACT ALL JACKS:** In any mode except Manual mode, pressing and releasing "Retract All Jacks" button retracts all the jacks completely. In Manual mode, the jacks will retract only while the "Retract All Jacks" button is held down.

**FRONT/REAR/LEFT/RIGHT:** Extends that pair of jacks while in manual mode.

### LIGHTS AND FUNCTION INDICATORS

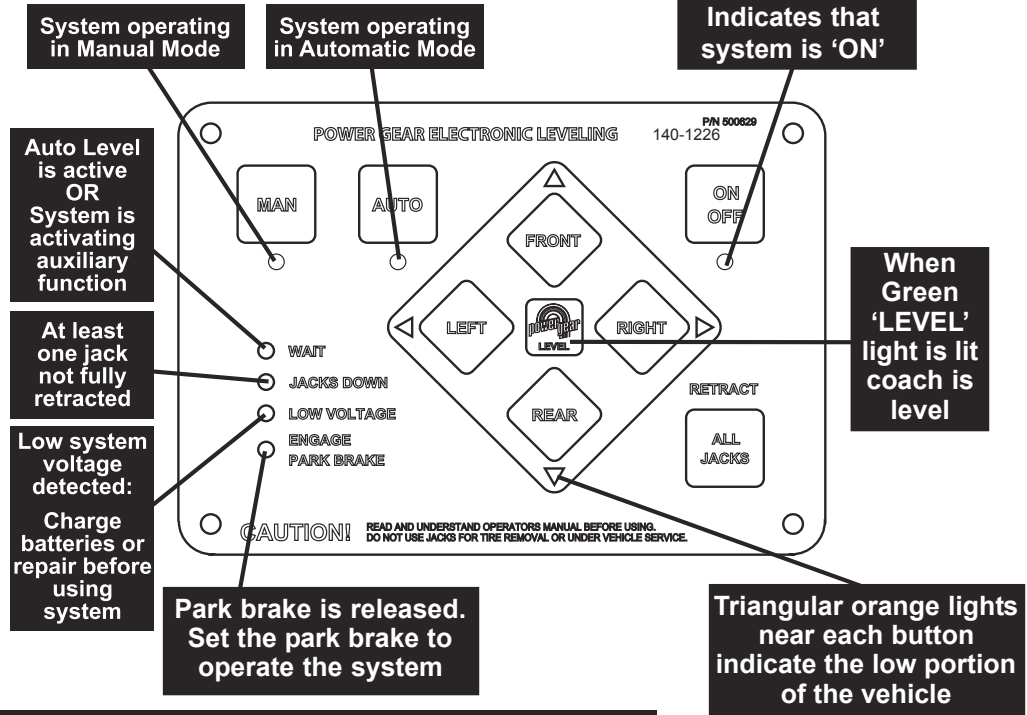

## Selecting A Site

When the coach is parked on an excessive slope, the leveling requirements may exceed the jack lift stroke capability. When this occurs, the 4 orange jack lights and the green "Power Gear Level" light in the center will blink together. The coach must be moved to a more level surface before the leveling jacks are deployed. On the contrary, if the green "Power Gear level" light in the center is on and/or blinking by itself, it means the coach is already level. You may, if you wish, operate the jacks anyway to act as a stabilizer.

## Automatic Leveling

1. Park the coach in a reasonably level area.
2. Put the transmission in "Park" if in a gasoline coach or "Neutral" if in a diesel coach.
3. Set the parking brake.
4. With the **Engine Running**, turn the control on by pressing the touchpad ON/OFF button. There will be a 10 second wait period for the system to stabilize. Verify that all jacks are fully retracted, "Jacks Down" light is not illuminated. (Auto leveling cannot start if the jacks are not fully retracted)
5. Press the AUTO button (Auto light turns on) NOTE: Movements in the vehicle while the system is auto leveling can cause false readings and improper operation. Passengers should remain seated.
6. Jacks will automatically extend to the ground after you press the AUTO button. After the jacks are on the ground, auto leveling begins.
7. The Front/Left/Right/Rear jacks will automatically extend as necessary until the control reaches the pre-programmed level position.
8. The Front/Left/Right/Rear lights show the side or end of the coach being leveled.
9. The Auto light will turn off when the system has been leveled and the center green "Power Gear Level" light will turn on.

### Manual Air Dump Feature

Some diesel models are equipped with a manual air bag dump switch. The air bags should be dumped before attempting to level the coach.

### Jack Retraction While In Auto Mode

To properly retract the jacks, press the "All Jacks" retract button. The jacks will retract to their fully retracted position. The "Jacks Down" light will turn off when all jacks are properly retracted.

# CAUTION

## PRODUCT DAMAGE

- Do not move vehicle until levelers are fully retracted ("Jacks Down" light not illuminated).
- Damage can occur to levelers, coach, surrounding property if the levelers are not fully retracted prior to vehicle being moved.

## Manual Leveling

1. Park the coach in a reasonably level area.
2. Put the transmission in "Park" if in a gasoline coach or "Neutral" if in a diesel coach.
3. Set the parking brake.
4. With the **Engine Running**, turn the control on by pressing the touchpad ON/OFF button. There will be a 10 second wait period for the system to stabilize. Verify that all jacks are fully retracted.
5. Press the MAN button (Manual light turns on).
6. If the jacks are fully retracted, the jacks will begin automatically extending. Jacks will stop when the ground is hit. The "Wait" light will blink while the jacks are automatically extending.
7. After the jacks are on the ground, manual features are available.
8. The Front/Left/Right/Rear lights show the side or end of the coach that needs to be extended to reach level. Push and hold the button next to the triangular orange light that is on.
9. Press the manual button when finished with manual mode. Manual light turns back off.

## Manual Override



**Before overriding an electric jack, keep all body parts clear of any**

**pinch points, such as between the wheel well opening and the top of the tire or the bottom of the luggage compartment and the ground. Anytime you are under the coach proper caution must be taken to keep clear of these pinch points. Failure to be aware of this could result in serious injury or death.**

In case of loss of power or communication to the jacks, an Emergency Manual Retract Procedure can be used to retract the jacks. To perform this procedure, READ ALL STEPS BEFORE ATTEMPTING TO MANUALLY RETRACT THE JACKS.

1. Turn off the ignition of the vehicle, engage parking brake, put transmission in "Park" for gas chassis applications and in "Neutral" for diesel chassis applications. Reinflate the airbags, if so equipped.
2. Verify that all personnel and tools are clear of the coach. Make sure that all personnel are out of the coach. Retract any slideout room that may be extended.
3. In the event that only communication has been lost with the jack, attempt to manually retract the jack by first applying 12 volts directly to the motor connections.
4. Disconnect the jack motor power plug at the motor. Connect extension power leads to the motor power plug so that the operator can stay out from underneath the coach during manual retract.
5. Apply 12 volts to the extension leads to retract the jack. 12 volt power can be supplied by either the coach or chassis 12 volt batteries. If a battery charger is available, this can be used to supply 12 volts to the leads. Ensure that the jack is retracting after applying power. If the jack is extending, reverse the power extension leads to retract the jack.

## Error Codes

An "Error Code" is indicated by certain lights on the touch pad blinking in a given pattern. Note the pattern indicated below and then find the corresponding mode, which explains the type of error encountered.

BLINKING LIGHT(S) PATTERN	MODE (ERROR)	BLINKING LIGHT(S) PATTERN	MODE (ERROR)
Front, right, rear and left blink in a clockwise pattern	Diagnostic Check (internal - occurs each time system is turned on and will shut off after a few seconds)	Wait	Wait until light turns off
		Low Voltage	Low Input Voltage (check battery)
"Power Gear" logo (green)	Level Achieved	All Lights Blinking & Buzzer	Jacks Down while traveling (jacks not fully retracted, drive-away mode will automatically retract all jacks)
Park Brake	Park Brake not set		All Lights Blinking
Wait & On/Off	Transmission not in park (gas) or neutral (diesel)	Front, right, rear, left & Power Gear logo	Excessive Slope

### Full Extension Protection

If, when operating the control in MANUAL mode, a condition occurs where any one jack of the extending pair reaches full extension, the control will automatically stop the extension of that pair of jacks. Any attempt to further extend that pair will be prevented by the control. The remaining jacks are still operational until they reach full extension.

### Manual Air Dump Feature

Some diesel models are equipped with a manual air bag dump switch. The air bags should be dumped before attempting to level the coach.

### Jack Retraction While In Manual Mode

The "Retract All Jacks" button will manually retract the jacks, but only while the button is held down. Continue to press the ALL JACKS retract button until the "Jacks Down" light turns off, indicating that all jacks have retracted

6. Retract each jack partially until all jacks have cleared the ground, then retract each jack completely.
7. If the motor does not function after applying 12 volts, the jack can be retracted manually using a ratchet, 16mm socket and extension (an electric drill may be used, if available).
8. Remove the rubber boot from the jack motor.
9. Depress the release handle lock and rotate the brake release handle counter-clockwise approximately 10 degrees. See fig.1.
10. Rotate the override nut located on the underside of the jack clockwise (looking from bottom or underneath). See figure 1.
11. Repeat for any other jack not retracted. Retract each jack partially until all jacks have cleared the ground, then retract each jack completely.
12. Make sure that all jacks are in the fully stowed position (jack foot pad all the way up to the bottom of the outside tube of the jack).



**Releasing the brake will result in the jack retracting while under load. The coach may immediately begin to lower. Make certain that you are clear of any pinch points before rotating the brake release handle. Failure to be aware of this condition could result in serious bodily injury or death.**

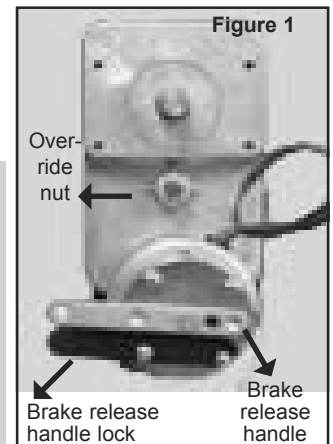

Figure 1

## Error Mode - Troubleshooting

If any problem is detected with the leveling system electronics or motors, the system will enter error mode.

If the AUTO and MAN lights are blinking together, the system is in Error Mode.

- Press the ON/OFF button to disable the buzzer. Make sure the light underneath the ON/OFF button is ON.
- To reset the system, press and hold the ON/OFF button for 3 seconds.
- The Front/Left/Right/Rear lights will tell you which jack is seeing an error. For example, if the Front and Left lights are blinking, the Left Front jack has the error. If the Right and Rear lights are blinking, the Right Rear jack has the error, etc.

When the error is first detected, the buzzer will sound alerting the user of the problem.

There are several things that can cause the control to go into Error Mode:

- Jack motor drawing too much current - short circuit.
- Jack motor drawing too little current-open circuit.
- Jack extending too long-sensor circuit.
- Jack retracting too long-sensor circuit.

If the buzzer continues to sound, the control is in "Emergency

Retract Mode". Verify that the coach is in park (neutral for a diesel engine) and the parking brake is engaged. The light and buzzer

should stop once the jacks are fully retracted.

ALL NORMAL FEATURES ARE DISABLED IN ERROR MODE. The intent of this mode is to allow the user or service technician to individually drive the jacks, in order to isolate the error. Please note that all additional error detection is disabled in this mode.

To assist in identifying and correcting jack problems you can operate the jacks independently while in error mode.

- To operate the left front jack, hold down the Left + Front buttons + "AUTO" to extend, OR "MAN" to retract the jack.
- To operate the right front jack, hold down the Right + Front buttons + "AUTO" to extend, OR "MAN" to retract the jack.
- To operate the left rear jack, hold down the Left + Rear buttons + "AUTO" to extend, OR "MAN" to retract the jack.
- To operate the right rear jack, hold down the Right + Rear buttons + "AUTO" to extend, OR "MAN" to retract the jack.

Once the cause of the error has been eliminated, you can exit error mode by pressing and holding the ON/OFF button for 3 seconds, then to retract the jacks by pressing the ALL JACKS RETRACT button. If all the jacks retract and all lights stop blinking then the system has been successfully reset.

- If the error has been eliminated, the jacks will fully retract and the Touch Pad will return back to normal.
- If the error has not been eliminated, the system will return back to error mode.

## Preventive Maintenance

1. Inspect and clean all electrical connections every 12 months
2. Remove dirt and road debris from jacks as needed.
3. Battery condition is important to the leveling system. Keep batteries fully charged when possible.

## Power Gear Limited Warranty

Power Gear warrants to the original retail purchaser that the product will be free from defects in material and workmanship for a period of (2) years following the retail sales date. Power Gear will, at its option, repair or replace any part covered by this limited warranty, which, following examination by Power Gear or its authorized distributors or dealers, is found to be defective under normal use and service. No claims under this warranty will be valid unless Power Gear or its authorized distributor or dealer is notified in writing of such claim prior to the expiration of the warranty period. Warranty is transferable pending documentation of original sale date of product.

WARRANTY SHALL NOT APPLY TO:

- Failure due to normal wear and tear, accident, misuse, abuse, or negligence.
- Products which are modified or altered in a manner not authorized by Power Gear in writing.
- Failure due to misapplication of product.

## Drive Away Protection

If the ignition is in the "Run" position, the jacks are down, and the operator takes the transmission out of neutral or park, or releases the parking brake, all of the LEDs will flash and the alarm beeper will activate. The system will then automatically retract the jacks until they are fully retracted. During this time the touch pad cannot be turned off.

- Telephone or other communication expenses.
- Living or travel expenses.
- Overtime labor.
- Failures created by improper installation of leveling systems, including final adjustments made at the plant, or low fluid level, wiring or ground problems.
- Replacement of normal maintenance items.

There is no other express warranty other than the foregoing warranty. THERE ARE NO IMPLIED WARRANTIES OF MERCHANTABILITY OR FITNESS FOR A PARTICULAR PURPOSE. IN NO EVENT SHALL POWER GEAR BE LIABLE FOR ANY INCIDENTAL OR CONSEQUENTIAL DAMAGES. This warranty gives you specific legal rights, and you may also have other rights, which vary from state to state. Some states do not allow the limitations of implied warranties, or the exclusion of incidental or consequential damages, so the above limitations and exclusions may not apply to you.

For service contact your nearest Power Gear authorized warranty service facility or call 1-800-334-4712. Warranty service can be performed only by a Power Gear authorized service facility. This warranty will not apply to service at any other facility. At the time of requesting warranty service, evidence of original purchase date must be presented.



1217 E. 7th Street  
Mishawaka, IN 46544  
800/334-4712  
www.powergearus.com



## Trouble Shooting Leveling Control Box 140-1224 Electric Jacks

© Copyright Power Gear Issued: January 2013

#82-L0524, Rev. OA

Touch Pad LED	Probable Cause	Solution
1. On/Off LED will not light	Ignition Key Turned Off	Turn on ignition key
	On/Off button not pressed on touch pad	Press on/off button on touch pad. NOTE: touch pad turns off after 4 minutes of inactivity.
	No +12 VDC on pin 5 of main power connector at control box	Repair wire or replace fuse, restore +12 VDC to pin 5 of main power connector. See wiring diagram
	No ground signal on control box ground lug	Check for ground on main ground lug at control box.
	No power on pin 3 of touch pad harness	Check control box output on pin 3 of touch pad connector. See wiring diagram. Inspect wire and connection at control box.
	No ground on pin 4 of touch pad harness	Check control box output on pin 4 of touch pad connector. See wiring diagram. Inspect wire and connection at control box.
2. Wait LED is Flashing	Jacks are extending or retracting in auto mode , control is busy	The control box is in the process of extending or retracting leveling jacks. Filling or dumping coach air bags.
3. On/Off LED and Wait LED are flashing together	No neutral signal detected at leveling control box	Check pin 2 and pin 6 on main power connector. See wiring diagram or document 82-E0029 at <a href="http://www.powergearus.com">www.powergearus.com</a> for correct input signals to control box.
4. Jacks Down LED is lit	Control box senses one or more jacks extended	Retract jacks, check jack limit switch sensors on jacks. See wiring diagram and use TIP sheet 11001 at <a href="http://www.powergearus.com">www.powergearus.com</a> .
5. Low Voltage LED is lit	Control box sensing low voltage	Check for at least 12VDC between pin 5 of the main power connector and control box ground lug. Check for at least 12 VDC between control box power lug and control box ground lug. See wiring diagram. Restore +12 VDC / ground to control box.
6. On/Off LED is On and Park Brake LED is Flashing together	Control box not sensing park brake signal	Set parking brake. See wiring diagram or document 82-E0029 at <a href="http://www.powergearus.com">www.powergearus.com</a> for correct input signals to control box.
7. Manual ,Auto, On/Off, and all 4 jack Directional LEDS flashing	Control boxes is in error mode, control box sensed low voltage during a leveling process	Start coach engine. Check power between control box power lug and control box ground lug for +12VDC. To reset the control box use document 3010002127 at <a href="http://www.powergearus.com">www.powergearus.com</a> .
8. All touch pad LEDS are flashing	Control box does not have a auto level reference point set	Use TIP sheet 11002 for control box with a revision level of OG, use Tip sheet 11003 for control boxes with revision level OK.
9. All touch pad LEDS are flashing and alarm is sounding	Control box is emergency retract the jacks	Either the park brake or the neutral signal was removed from the control box at the main power connector while the jacks were extended. See wiring diagram or document 82-E0029 at <a href="http://www.powergearus.com">www.powergearus.com</a> for correct input signals to control box.



Touch Pad LED	Probable Cause	Solution
10. Manual, Auto and Two Directional LEDS Flashing	Jack motor drawing higher than 15amps DC	Test jack motor per document 82-L0501 at <a href="http://www.powergearus.com">www.powergearus.com</a> . NOTE: Jack motor normal operating amp draw is 4-8 amps DC.
	Jack motor brake defective	Inspect / Replace jack brake per document 3010001428 at <a href="http://www.powergearus.com">www.powergearus.com</a> . NOTE: Jack motor normal operating amp draw is 4-8 amps DC.
	Jack motor harness is broken or shorted out	Inspect / test jack motor harness. Replace wiring harness. See wiring diagram.
	Jack limit switch sensor harness is broken or shorted out	Inspect / test jack limit switch harness. Replace wiring harness. See wiring diagram. Use TIP sheet 11001 at <a href="http://www.powergearus.com">www.powergearus.com</a> .
	Jack limit switch harness plug into wrong jack	Verify that correct jack limit switch harness is plugged into correct jack. See wiring diagram.
	Jack motor harness plugged into the wrong port at control box	Verify that the correct jack motor harness is plugged into the correct control box port.
	Loose connection on jack motor harness	Verify that jack motor harness connections at jack assembly and control box are seated properly and making good contact. See Wiring diagram.
	Loose connection on jack limit switch sensor harness	Verify that jack limit switch sensor harness connections at jack assembly and control box are seated properly and making good contact. See Wiring diagram.

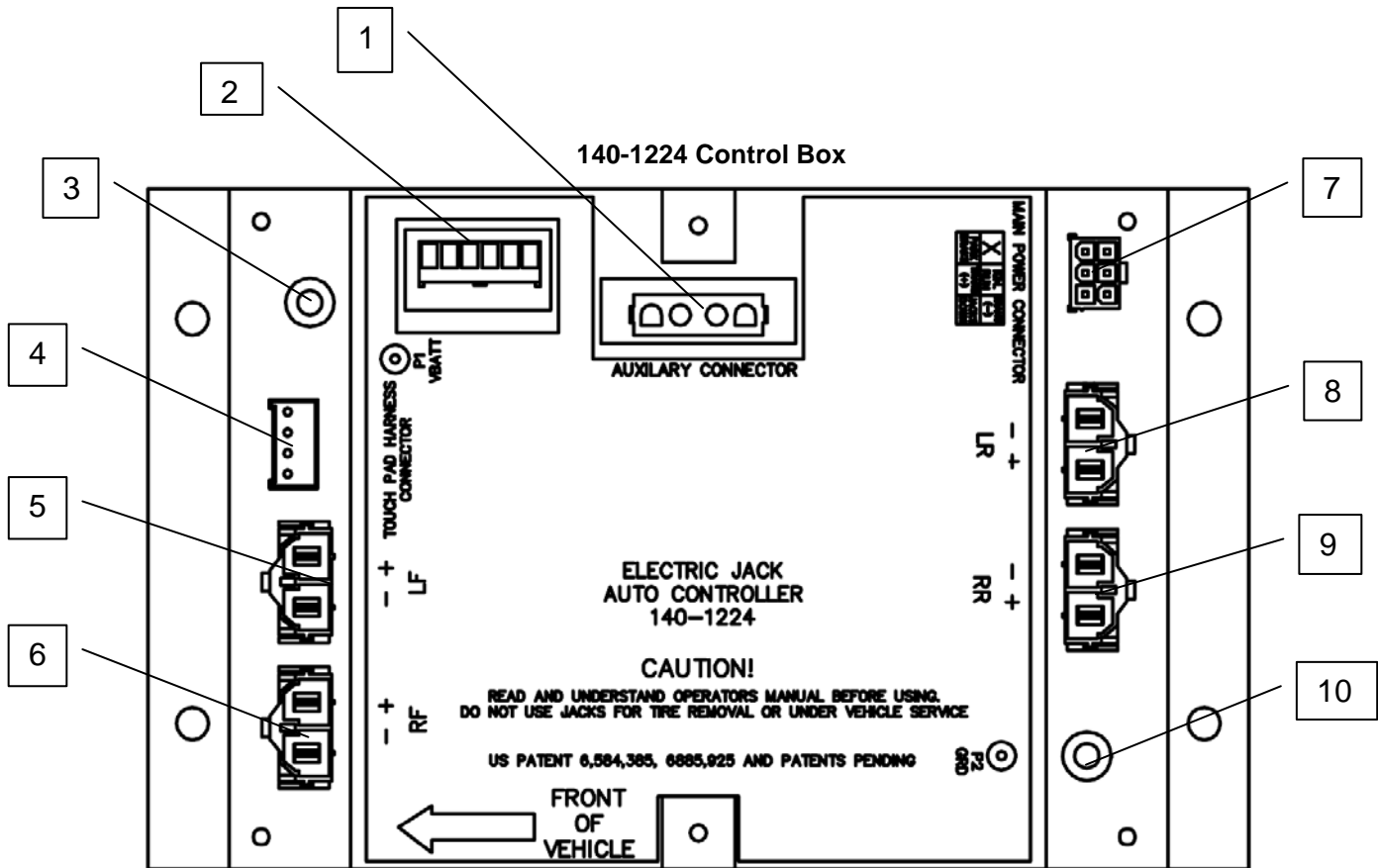

**Item #1-Auxiliary Harness Connector**

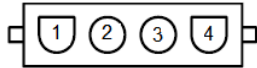

- Pin#1** Fill output to the airbag valve. Energized with +12vdc to fill airbags.
- Pin#2** Fill output to the airbag valve. Ground to fill airbags.
- Pin#3** Dump output to the airbag valve. Energized with +12vdc to dump airbags.
- Pin#4** Dump output to the airbag valve. Ground to dump airbags.

**Item #2- Limit Switch Connector**

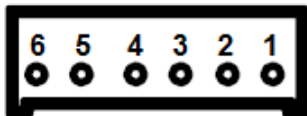

- Pin#1** Output 12vdc to limit switches
- Pin#2** Input left front limit switch
- Pin#3** Input right front limit switch
- Pin#4** Input left rear limit switch
- Pin#5** Input right rear limit switch
- Pin#6** Output ground to limit switches

**Item #3-V Battery Lug**



**Pin #1** Input +12vdc from battery

**Item #4-Touch Pad Harness Connector**



- Pin #1** Output to the touch pad. Transmit signal 5-7vdc.
- Pin #2** Input from the touchpad. Receive signal 5-7vdc.
- Pin #3** Power (+12vdc) output to the touch pad.
- Pin #4** Ground output to the touchpad.

**Item #5-Left Front Jack Motor Connector**



- Pin#1** Output to jack motor
- Pin#2** Output to jack motor

Note: Pin #1 and pin #2 change polarities depending on jack extending or retracting.

**Item #6-Right Front Jack Motor Connector**

**Pin#1** Output to jack motor  
**Pin#2** Output to jack motor

Note: Pin #1 and pin #2 change polarities depending on jack extending or retracting.

**Item #8-Left Rear Jack Motor Connector**

**Pin#1** Output to jack motor  
**Pin#2** Output to jack motor

Note: Pin #1 and pin #2 change polarities depending on jack extending or retracting.

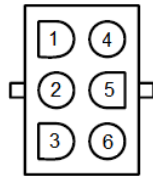
**Item #7- Main Power Connector**

- Pin#1** Input from park brake. Has continuity to ground when the park brake is engaged.
- Pin#2** Input from neutral safety switch. Can measure as either +12vdc or ground.
- Pin#3** Not used.
- Pin#4** Not used.
- Pin#5** Input from ignition. Energized with +12vdc when the coach is running.
- Pin#6** Input from neutral safety switch. Can measure as either +12vdc or ground.

**Item #9-Right Rear Jack Motor Connector**

**Pin#1** Output to jack motor  
**Pin#2** Output to jack motor

Note: Pin #1 and pin #2 change polarities depending on jack extending or retracting.

**Item #10-Ground Lug**

**Pin #1** Input Ground from chassis

# Wiring Diagram

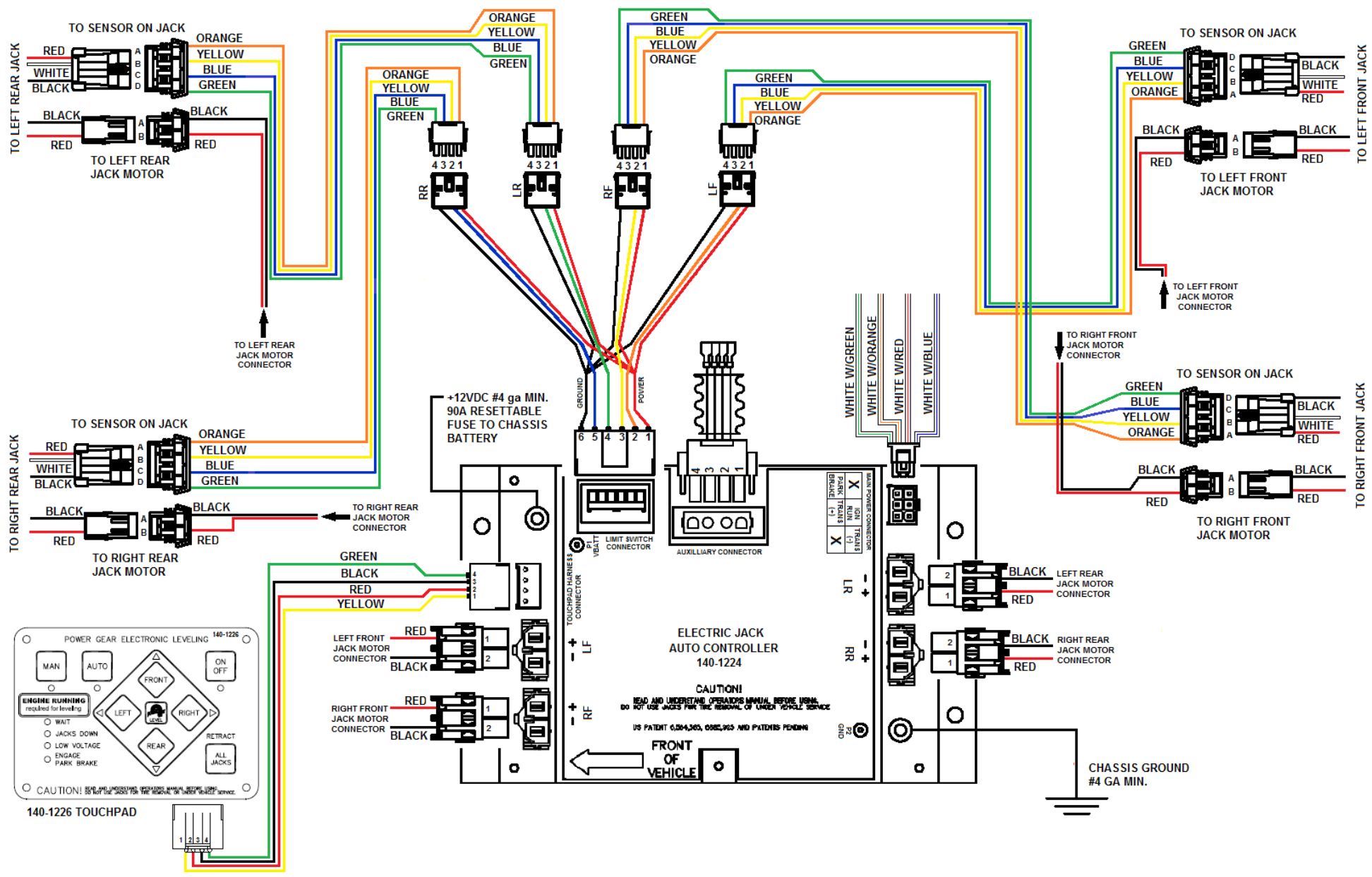

**140-1226 TOUCHPAD**

POWER GEAR ELECTRONIC LEVELING 140-1226

MAN AUTO ON OFF

ENGINE RUNNING (required for leveling)

WAIT

JACKS DOWN

LOW VOLTAGE

ENGAGE

PARK BRAKE

RETRACT

ALL JACKS

FRONT

LEFT RIGHT

REAR

CAUTION! DO NOT USE JACKS FOR THE REMOVAL OF UNDER-VEHICLE SERVICE.

# Wiring Diagram Continued

## LEFT FRONT JACK ASSEMBLY COMPLETE CIRCUIT

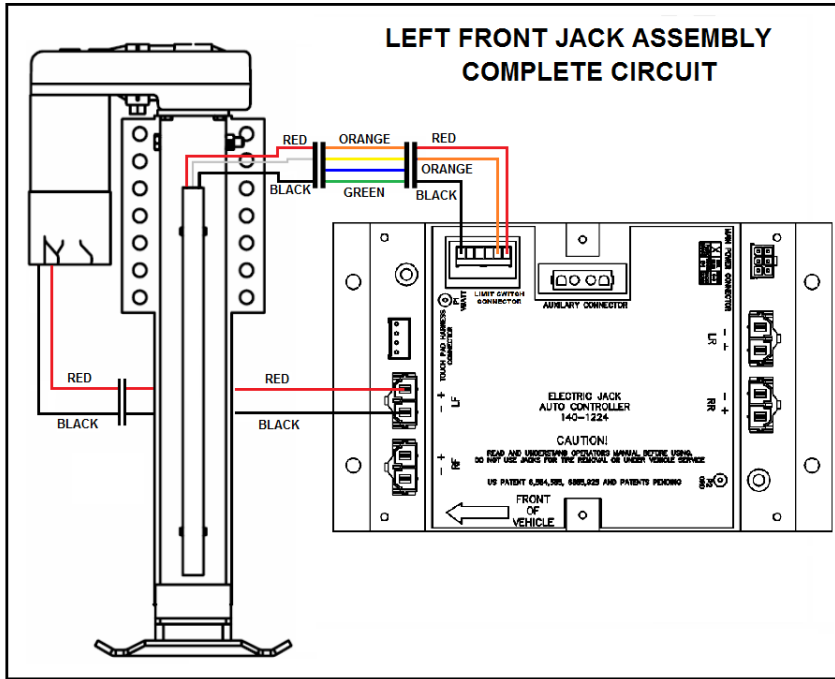

## RIGHT FRONT JACK ASSEMBLY COMPLETE CIRCUIT

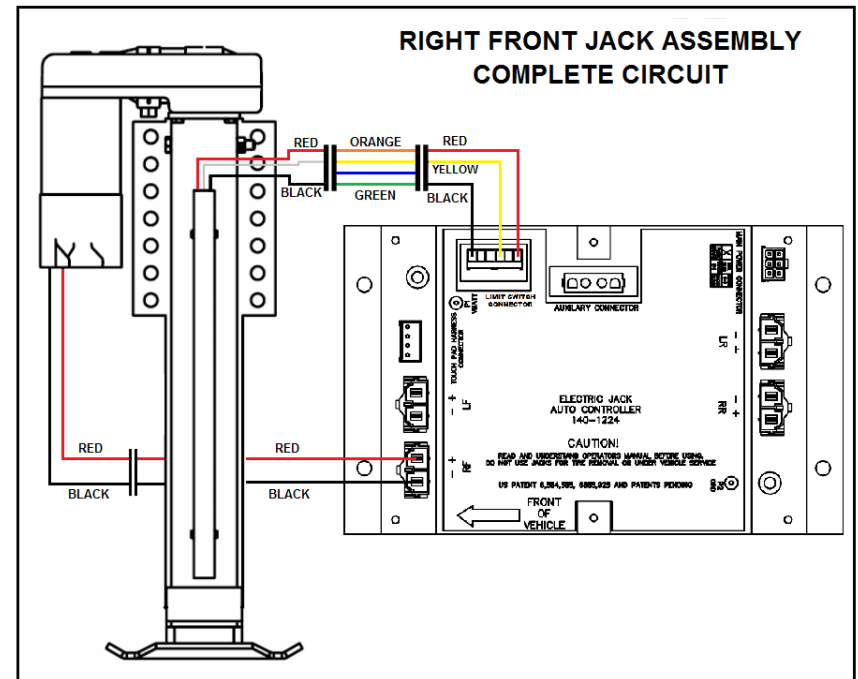

## LEFT REAR JACK ASSEMBLY COMPLETE CIRCUIT

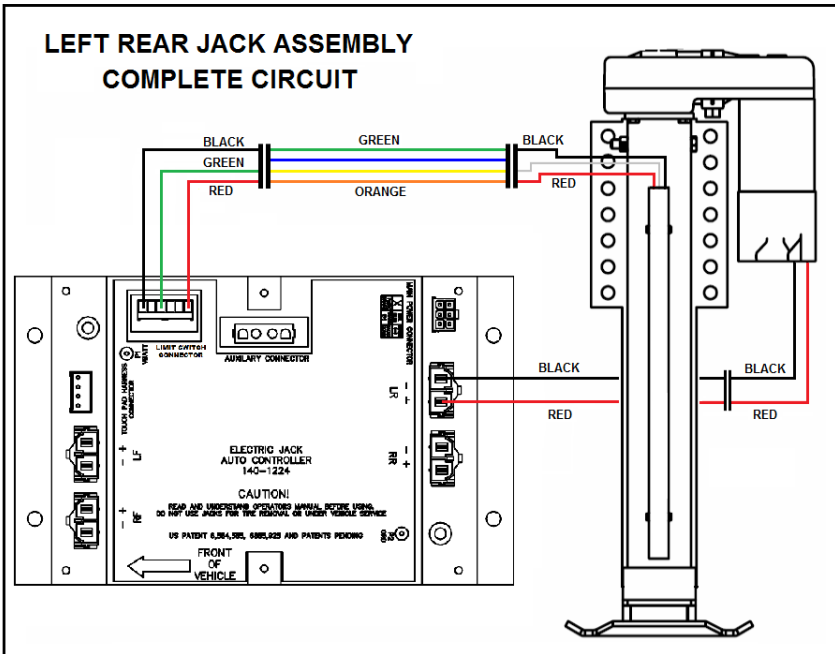

## RIGHT REAR JACK ASSEMBLY COMPLETE CIRCUIT

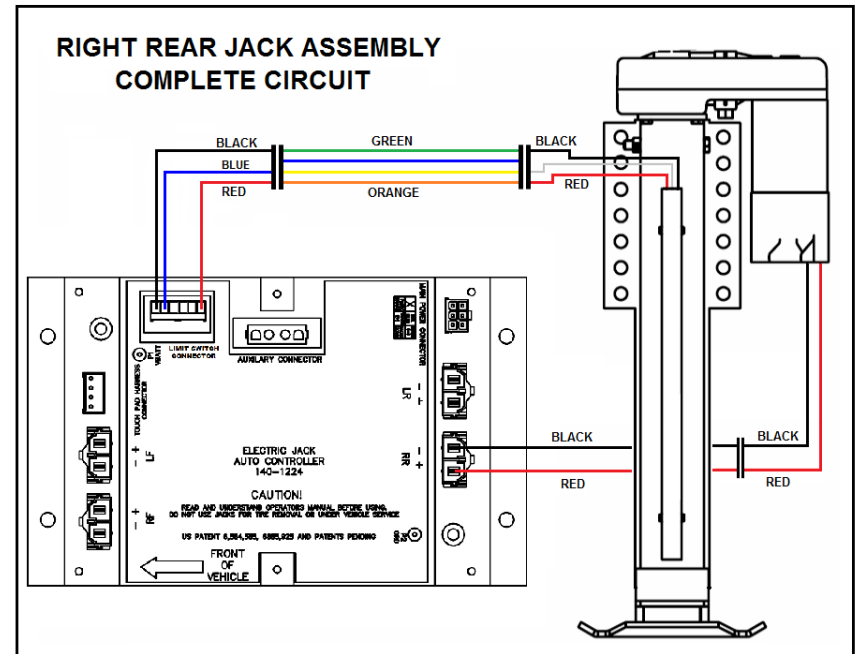

Additional reference Publication located at  
[www.powergearus.com](http://www.powergearus.com)

- 82-L0368 Operators manual for electric leveling control box 140-1224 rev OK
- 82-L0501 Testing the electric jack motor brake
- 11001 Electric leveling Sensor circuit function check
- 11002 Electric leveling installation and calibration of control box 140-1224 rev OG
- 11003 Electric leveling installation and calibration for control box 140-1224 rev OK
- 3010000914 Electric leveling calibration of control box 140-1224 rev OK
- 3010001163 Replacement of electric leveling jack motor
- 3010001428 Electric leveling motor brake kit replacement instructions
- 3010002127 Electric jack error mode resetting procedure
- 3010002134 Replacement of the electric leveling jack drive pin using pin kit 1010001889
- 3010002151 Low voltage indication for hydraulic and electric leveling controls



# Electric Jack Error Mode Resetting Procedure

© Copyright PowerGear Issued: 10/11

# 3010002127, Rev. 0C 11/12

## NOTE

COACH ENGINE MUST BE RUNNING WHEN THE LEVELING SYSTEM IS IN USE AND OPERATIONAL.

## NOTE

If the control is left with the ignition on while in error mode it will eventually time out and shut off HOWEVER the error mode LED's will still flash. If you attempt the procedures outlined in this document without the touchpad on, it will not respond. If it times out and shuts down, simply press and release the ON/OFF button to illuminate the LED underneath.

## WARNING

WHEN IN SENSOR OVERRIDE MODE THE JACK CAN BE OVER EXTENDED OR OVER RETRACTED WHICH WILL CAUSE DAMAGE AND FAILURE OF THE JACK LEG. IF THIS OCCURS WARRANTY WILL NOT COVER THIS DAMAGE!

1217 E. 7<sup>th</sup> St.  
Mishawaka, IN 46544  
www.powergearus.com



### READ, UNDERSTAND AND FOLLOW THESE INSTRUCTIONS

When the control is in error mode the **MAN** and **AUTO** lights will flash along with the corresponding arrow lights on the touchpad. The arrow lights indicate which jack is in error. **See Figure 1.** The control will go into error mode for one of 4 reasons:

1. A high amp draw from the motor, this is 15 amps or higher. The normal running amps are 4-8 amps.
2. Wire(s) with a short to ground on the motor harness or sensor harness.
3. Wire(s) or connector(s) with an open circuit on the motor harness or sensor harness.
4. If all the arrow lights (**Left, Front, Right and Rear**) are flashing this indicates the power was disrupted during jack operation. This can occur if the ignition is cycled or shut off or power loss at the control box at terminals P1 VBATT and P2 GND.

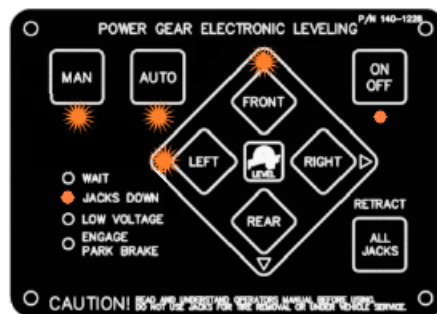

Figure 1 Showing Error Mode

**Example: Left arrow light and Front arrow light would indicate the left front jack has experienced an error. See Figure 1.**

The system looks for errors in a rotating clockwise pattern starting with the left front jack.

1. **Using the touch pad you will need to extend each jack leg 4 to 6 inches to correctly reset the system.** You will need to start with the leg that is indicating an error.



Figure 2 Hold down for 8 seconds

2. **Example: Touchpad is indicating the Left Front is in error. See Figure 2.** Press the Auto, Left and Front buttons at the same time and hold them down for 8 seconds. If the 3 lights are rapidly flashing this is indicating the jack is moving. If the touchpad begins to beep while holding the buttons, you should release them as this indicates the procedure is not working. **See Step 3.**

3. If the touchpad is beeping while attempting to extend the jack leg the procedure in step 2 is not working and the jack leg is not moving. In this case the **Sensor Override Mode** can be tried (**see warning to the left**). This is shown in **Step 4.**

## ! WARNING

WHEN IN SENSOR OVERRIDE MODE THE JACK CAN BE OVER EXTENDED OR OVER RETRACTED WHICH WILL CAUSE DAMAGE AND FAILURE OF THE JACK LEG. IF THIS OCCURS WARRANTY WILL NOT COVER THIS DAMAGE!

## ! NOTE

Further troubleshooting documents can be found on our website at [www.powergearus.com](http://www.powergearus.com).

TIP 11001 – Sensor Circuit Function Check

82-L0501 – Testing Electric Jack Motor Brake

TIP 11002 – Electric Jack Controller Install & Calibration REV OG

TIP 11003 – Electric Jack Controller Install & Calibration REV OK

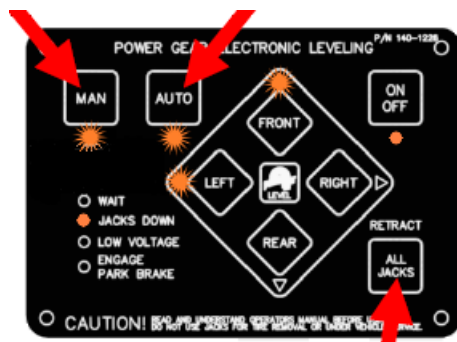

**Figure 3 Sensor Override Mode: Pressing Auto, Manual And All Jacks Retract**

4. To enter into **Sensor Override Mode** (see warning to the left) press the following 3 buttons at the same time: **MAN/AUTO/ALL JACKS RETRACT**. See *Figure 3*. You will hear 3 beeps and then release the buttons. **Then attempt step 2 above again.**

You may have to repeat the **Sensor Override Mode** procedure for each jack at **least 3 times**.

If the jack that is in error does not extend in sensor override mode after 3 tries, the reset procedure cannot be completed and further troubleshooting of the jack will be needed. See your Operator's Manual (82L-0368) for manual jack retraction instructions. Technical documents can be obtained on our website at [www.powergearus.com](http://www.powergearus.com). See the note to the left for document information.

5. If you are successful in getting all 4 jacks extended for 4-6 inches, **VISUALLY VERIFY** this before going to next step. **If you proceed to step 6 and take the system out of error mode without all 4 jacks being extended, the system will show Jacks Down and pressing the Retract All Jacks button at this point could break the pin in the jack that was not extended down. The ability to control each jack independently is lost once the system is taken out of error mode.**
6. Next, depending on what revision level control box (140-1224) you have on your coach (**REV OG or REV OK**) take the control out of error mode as follows:
  - a. **Revision OG:** Press and hold all 4 of the arrow buttons: **left/right/front/rear at the same time** until you hear a single tone. Release the buttons.
  - b. **Revision OK:** Press and hold the **On/Off button** until you hear a single tone. Release the button.
7. After receiving the beep using one of the methods above, the Man and Auto lights will stop flashing. At this time press and release the Retract All Jacks button and all jacks will start to retract. The Wait light will flash while the jacks are retracting. If the system is functioning properly, when the jacks finish retracting the Jacks Down LED will go out and the Wait LED will stop flashing.
8. If the system goes back into Error Mode (MAN, AUTO and any two arrow lights flashing) you will need to retract the jacks manually.

**If the jacks are extended, you do not need to bring them up manually unless the reset procedure is unsuccessful. Manual override of the electric jacks is covered on page 3 of the operator's manual (82-L0368). This manual and other information is available on our website at [www.powergearus.com](http://www.powergearus.com).**

9. Contact your OEM or Service Facility if additional assistance is needed.





# ELECTRIC LEVELING MOTOR BRAKE REPLACEMENT INSTRUCTIONS

© Copyright PowerGear Issued: December, 2007

#3010001428, Rev. 0B August, 2011

## Contents

Inspection	1
Installation	2
System Test	5

## NOTE

Inspection is not required for boots with metal clamps (FIGURE 4) or boots with an extra band seal just above the existing boot (FIGURE 5)

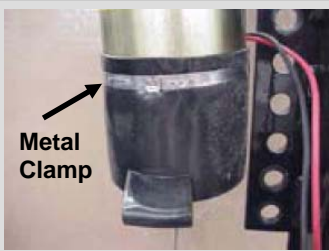

Figure 4



Figure 5

## WARNING

**DO NOT WORK ON OR AROUND A VEHICLE THAT CAN BE MOVED.** To ensure personal safety, place the transmission into PARK (NEUTRAL) and set the parking brake. Turn off the ignition and remove the ignition key. Maintain control of keys while working. Attach a notice, "DO NOT USE", to the ignition switch in order to prevent activation of the systems.

## Electric Leveling Motor Brake Replacement Instructions

### Inspection

The electric leveling jack motor may become inoperative due to moisture entering the motor brake boot causing corrosion. The following instructions are inspection and repair of this condition.

1. To inspect the motor brake, safely cut the old plastic wire tie and rubber boot. Remove these items from the motor and discard (see FIGURE 1).
2. Inspect the condition of the brake. Any brake with no evidence of corrosion (FIGURE 2) is in good condition and will only require a new boot installation (see *Installation of Boot Replacement Kit*, page 2). Any brake with evidence of corrosion (FIGURE 3) will require a new brake and boot installation (see *Installation of Motor Brake Service kit # 1010001289*, page 2).

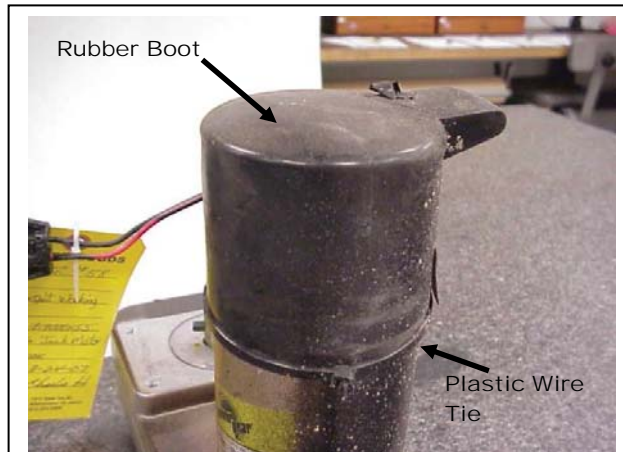

Figure 1

**Boot Removal**



Figure 2 **Good Condition**



Figure 3 **Bad Condition**



**NOTE**

If brake is in GOOD condition (FIGURE 2) but motor does not operate when 12V is directly applied, replace with motor service kit.

LH motor kit: 1010001018  
RH motor kit: 1010001019

*Installation of Boot Replacement Kit #1010001232*

1. Slide the metal clamp around the motor housing and hold in place (FIGURE 6).
2. While holding the clamp in place, slide the new boot around the motor housing making sure that the motor brake handle fits inside the duck-bill (see FIGURE 8) in the boot.
3. Position the clamp over the boot, approximately 1/4" from the edge of the boot.
4. Using Oetiker Pincer pliers (readily available via the internet, if not found locally with a tool supplier), crimp the raised part of the clamp until it tightens around the boot (see FIGURE 7). The deformation of the clamp ear provides a visible and instant check that closure has been accomplished (see FIGURE 7a).

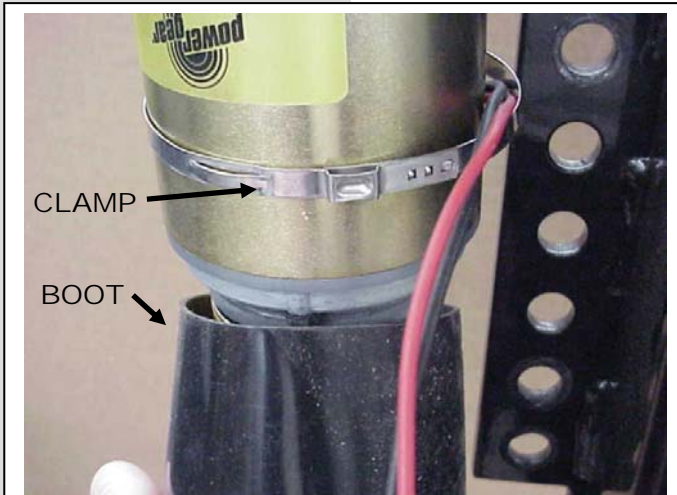

Figure 6

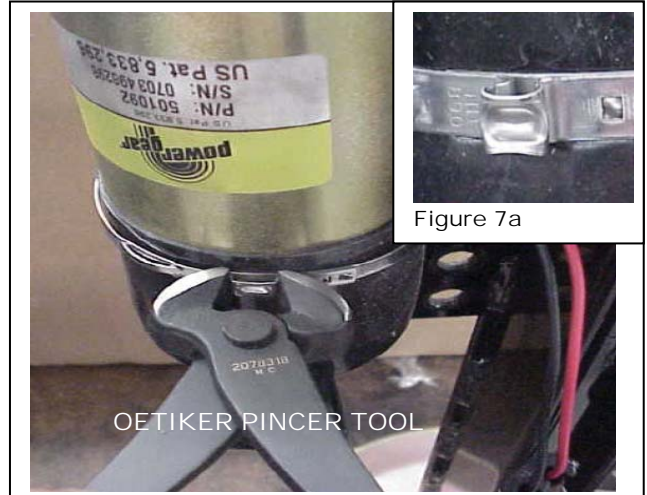

Figure 7

Figure 7a



Figure 8

**NOTE:** In cases where the electric jack assembly is mounted where water spray from the tire will come in direct contact, it is recommended to apply a continuous bead of RTV silicone around the perimeter of the edge of the boot.



*Installation of Motor Brake Service Kit #1010001289*

1. Remove the four screws that attach the brake to the motor.
2. Remove the two screws and washers that attach the spacer to the motor.

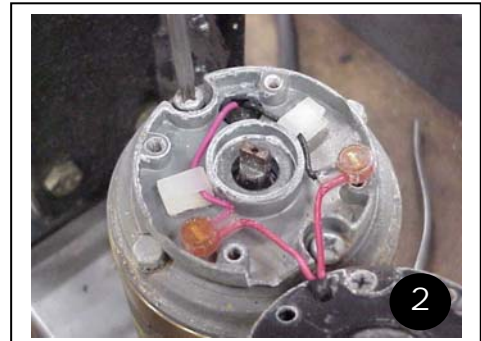

**NOTE**

A breakdown of Motor Brake Service Kit 1010001289 is shown on Page 5, FIGURE 9 of this tip sheet.



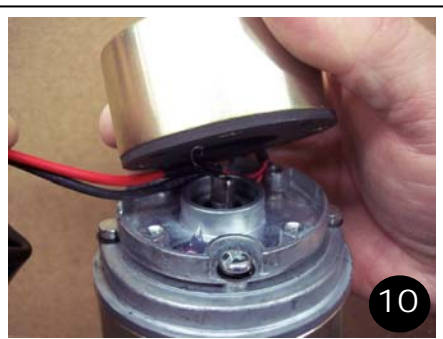
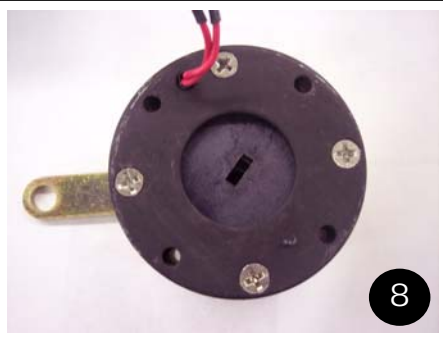
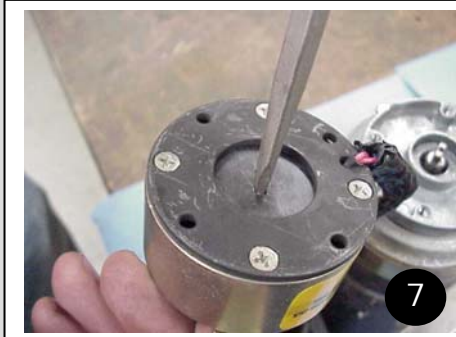

3. Lift the spacer, and cut the wires leading to the brake flush with the motor.
4. Apply RTV silicone sealant over exposed wires.
5. Install new spacer with the slot in the spacer oriented as shown.
6. Install the two screws and washers, and tighten to 18-20 in/lbs.
7. In preparation to install brake to motor, it may be necessary to turn the brake disc to orient the slot in the brake with the motor tang. This can be accomplished by releasing the brake lever and using a screw driver to manually turn the brake disc to the desired location.
8. Align slot in brake with the mounting holes. Orient brake lever to match existing.
9. Turn motor shaft to align with mounting holes
10. Install brake onto motor, wrap wires, and insert them through the slot in the spacer.

**Note:** If you suspect that a wire may be pinched between the spacer and the brake, use a multimeter to check for continuity between each brake wire and the motor housing. If brake was installed properly, there should NOT be continuity.

## ⚠ CAUTION

BE CAREFUL NOT TO  
TWIST OR CUT WIRES ON  
EDGE OF SPACER



11



12

11. Make sure wires are not pinched in the slot of the spacer.
12. Install brake screws. Make sure of washer location. Torque to 14-16 in/lbs.
13. Slide clamp over harness, boot, and motor

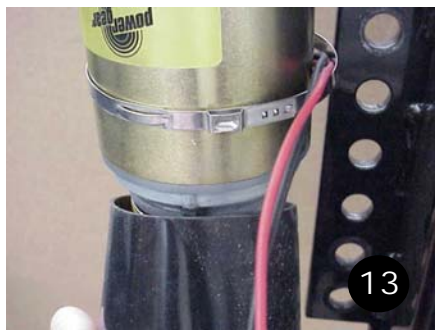

13

14. Now slide the clamp over the boot, approximately 1/4" from the edge of the boot. Using Oetiker Pincer pliers (readily available via the internet, if not found locally with a tool supplier), crimp the raised part of the clamp until it tightens around the boot. The deformation of the clamp ear provides a visible and instant check that closure has been accomplished (14a).



14a

14

**NOTE:** In cases where the electric jack assembly is mounted where water spray from the tire will come in direct contact, it is recommended to apply a continuous bead of RTV silicone around the perimeter of the edge of the boot.



15. Install new jumper harness to both the brake and motor harness connectors. Connect jumper harness to jack power distribution harness on the coach. **Note:** jumper harness wire colors may not match coach harness colors. This is ok.

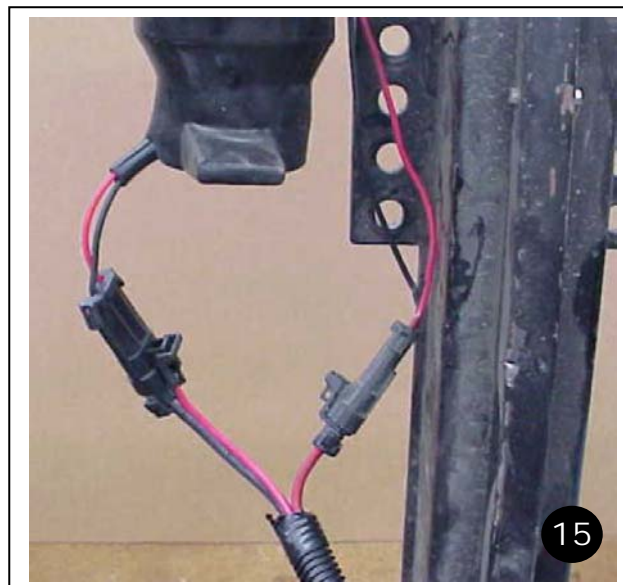

15

LABOR ALLOWANCE:

- 1010001232 Motor Boot Service Kit: 30 minutes per jack
- 1010001289 Motor Brake Service Kit: 30 minutes per jack



## ! WARNING

DO NOT WORK ON OR AROUND A VEHICLE THAT CAN BE MOVED. To ensure personal safety, place the transmission into PARK (NEUTRAL) and set the parking brake. Turn off the ignition and remove the ignition key. Maintain control of keys while working. Attach a notice, "DO NOT USE", to the ignition switch in order to prevent activation of the systems.

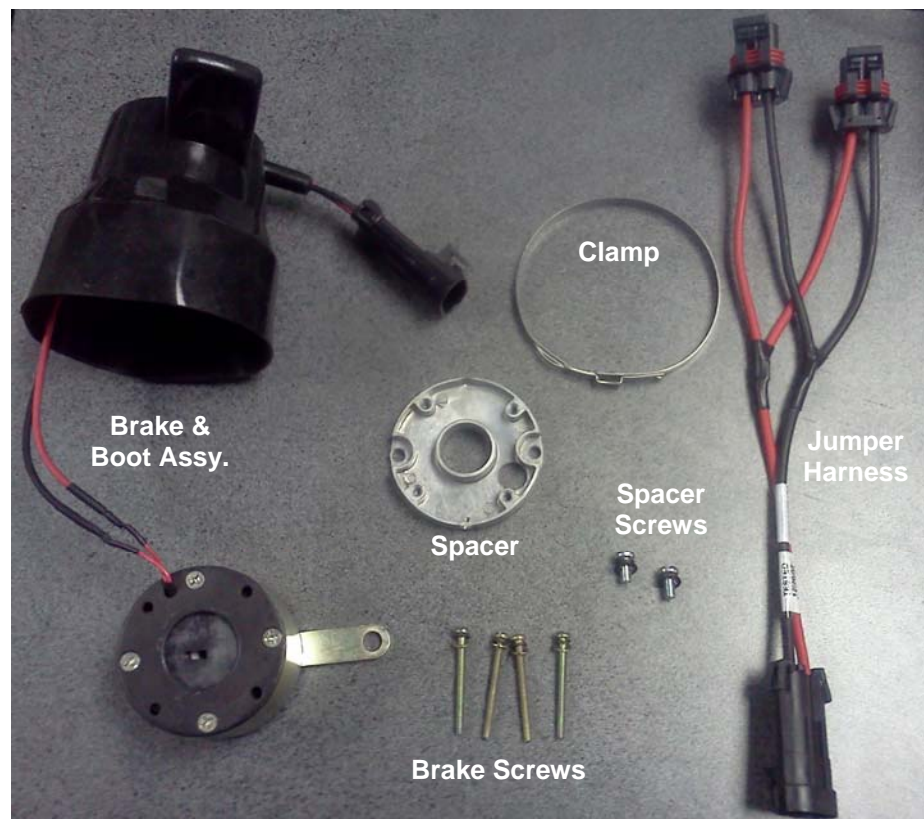

Figure 9 Motor Brake Service Kit # 1010001289

### System Test

Perform an auto level cycle to ensure repairs were properly completed

#### TO BEGIN LEVELING OPERATION

1. Engine must be running
2. Transmission must be out of gear (this could be "Park" or "Neutral", depending on your transmission).



# Tip Sheet

## Electric Leveling Drive Pin Removal & Replacement for Kit 1010001889

© PowerGear 1/09 3010002134 Rev. 0A

### Electric Leveling Drive Pin Removal and Replacement

#### Removal & Replacement of Pin Procedure



**WARNING**

Before working underneath any coach, proper support of the chassis must be undertaken. Failure to properly support the coach can result in injury or death.

1. Park the motor home on a paved, level surface.
2. Place the transmission into Park (Neutral) and set the parking brake.
3. Turn off the ignition and remove the ignition key. Retain control of the keys until all repairs are complete.
4. Verify that the leveling jacks are fully retracted before proceeding.

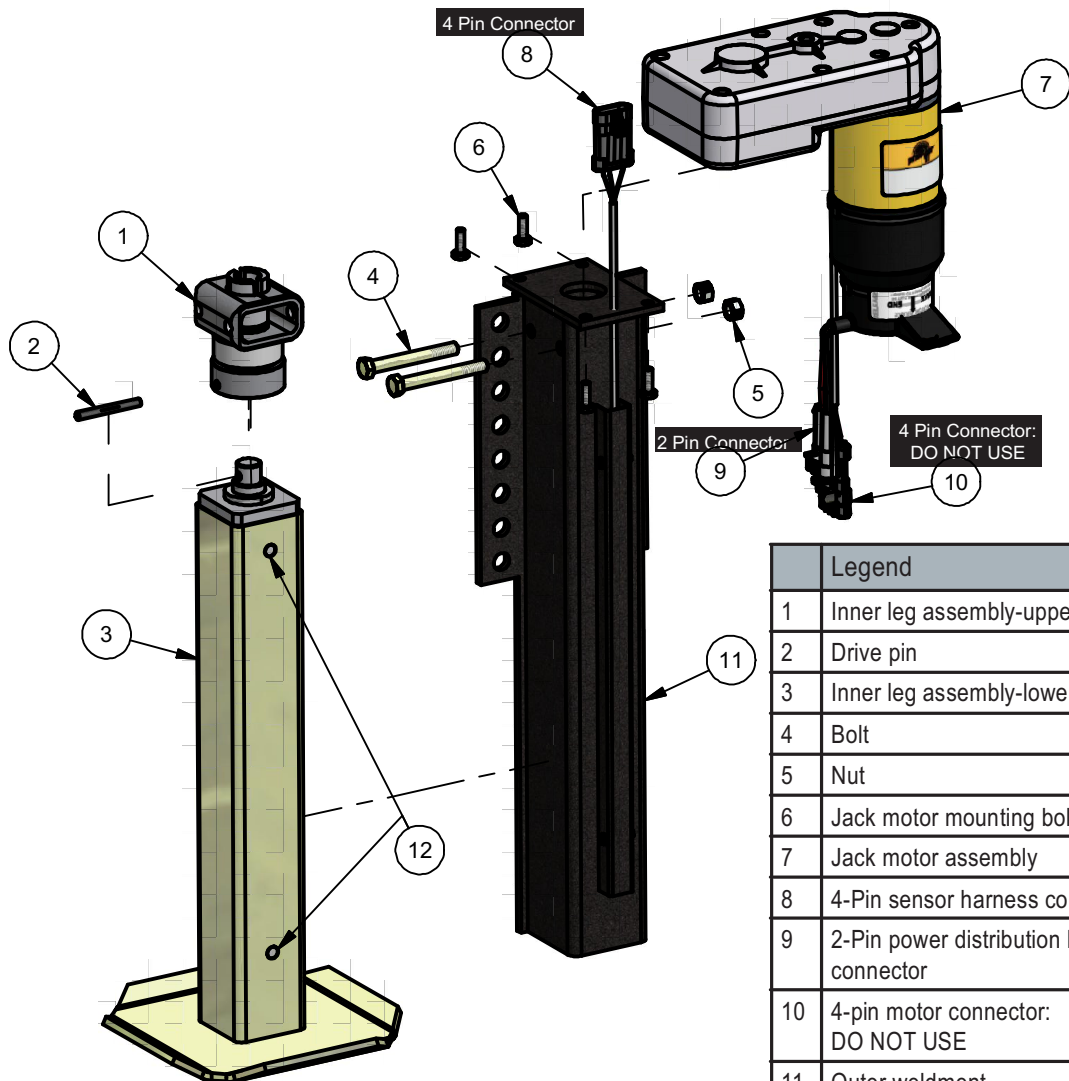

Legend	
1	Inner leg assembly-upper
2	Drive pin
3	Inner leg assembly-lower
4	Bolt
5	Nut
6	Jack motor mounting bolts
7	Jack motor assembly
8	4-Pin sensor harness connector
9	2-Pin power distribution harness connector
10	4-pin motor connector: DO NOT USE
11	Outer weldment
12	Sensor Magnet



1217 E. 7th Street  
Mishawaka, IN 46544  
800.334.4712  
PowerGearSolutions.com

**Removal & Replacement Procedure, cont'd...**

**NOTE: Perform Steps 5-6 only if necessary to gain access to the jack mounting bracket.**

5. Place a heavy duty floor jack under the chassis frame near the axle and raise the tire off the ground in order to obtain enough clearance to access the jack mounting location.
6. Place a heavy duty jack stand under the frame near the floor jack, then slowly lower the floor jack until the coach weight is supported by the jack stand.

**Refer to the Assembly diagram on Page 1 to perform Steps 7-22.**

7. Unplug the 2-pin leveling jack motor harness connector (Item #9) from the power distribution harness.
8. Disconnect the 4-pin sensor harness connector from the plug (Item #8) on the jack leg.
9. Remove the leveling jack by unfastening the hardware connecting the jack to the mounting bracket. Make note of which holes were used on the jack leg to fasten it to the mounting bracket. Retain the leveling jack and all fastening hardware for later reinstallation.
10. Place the jack on a sturdy work surface.
11. Remove the four bolts fastening the motor assembly to the jack. (Item #6). Retain the bolts and motor for reassembly. Note orientation of motor before removing from leg.
12. Remove the two sets of bolts and nuts (Items #4&#5) from the outer weldment (#11). Retain all hardware for reassembly.
13. Slide the inner leg assembly out of the outer weldment.
14. Use a punch to remove the drive pin (Item #2) from the two sections of the inner leg assembly (Items #1 & #3). Support Items #1 & #3 of the inner leg during pin removal. Discard the original pin.
15. Remove any dirt or debris from the holes for the pin on both Items #1 & #3, then reposition the sections so the retaining pin holes are aligned.
16. Obtain a new drive pin. Apply a thin line of Loctite 680 retaining compound (included) to both the pin (Item #2) and the hole in Item #1 per the manufacturer's recommendation on the back of the retaining compound bag.
17. Drive the new drive pin into place in the same direction the old pin was removed. After installation, the ends of the pin should be flush with the surface of the top drive of the inner leg. Support Items #1 & #3 of the inner leg during pin insertion.
18. Reinstall the inner leg assembly by sliding into the outer weldment. Verify the two magnets (Item #12) are seated properly and are aligned with the sensor. Fasten with existing nuts and bolts. Torque bolts to 30 ft-lbs.
19. Reinstall the motor assembly using original bolts. (Item #6). Torque bolts to 15 ft-lbs.
20. Reinstall the leveling jack assembly to the mounting bracket on the motor home chassis in its original location using existing bolts. Torque the mounting bolts to 90 ft-lbs.
21. Reconnect the leveling jack motor plug (Item #9) to the power distribution harness.
22. Reconnect the 4-pin sensor harness plug to the plug at the top of the jack leg (Item #8).

**NOTE: The jack motor may have been equipped with a 4-pin connector. DO NOT USE this connector.**

23. Repeat Steps #7 - #22 to replace the drive pins in the remaining jacks, except for any jack that was completely replaced.
24. If a floor jack and jack stands were used during repairs: Remove the jack stands, then lower and remove the floor jack.
25. Test the operation of the jacks by performing an automatic leveling cycle per the Electric Jack Operator's Manual. If jack operation results in a malfunction of the system, refer to Power Gear Tip Sheet #3010002127, Electric Jack Error Mode Resetting Procedure.



# Tip Sheet #11001

## Sensor Circuit Function Check Electric Leveling

© Power Gear 5/08 Tip Sheet #11001 Rev 0A

### Electric Leveling Sensor Circuit Function Check

#### Instructions



#### WARNING

Extreme caution must be used when attempting to manually retract the hydraulic leveling jacks. Access to the manual override valves is at the hydraulic power unit that is generally mounted on the coach where accessibility is limited. Failure to heed all warnings may result in serious injury or death.

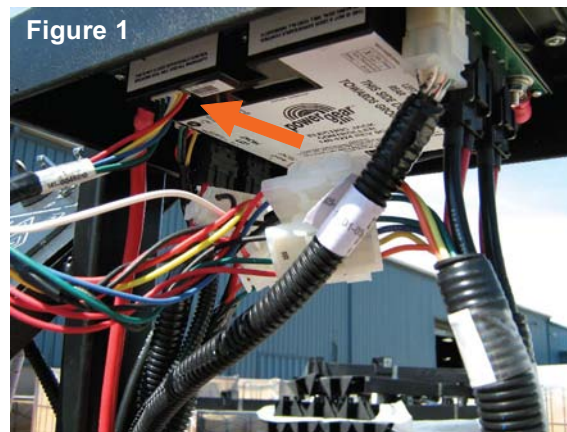

Figure 1

1. The sensor harness is plugged into the leveling controller (*see figure 1*).

The sensor circuit is used to indicate jack position, either fully retracted or fully extended.

The sensor is a hall type and is powered by the control. A magnet is mounted onto the jack inner leg and triggers the sensor when it passes.

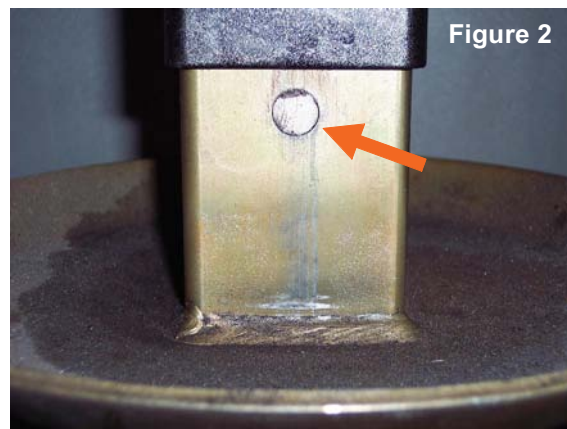

Figure 2

2. Magnet on the leveling inner leg (*see figure 2*).

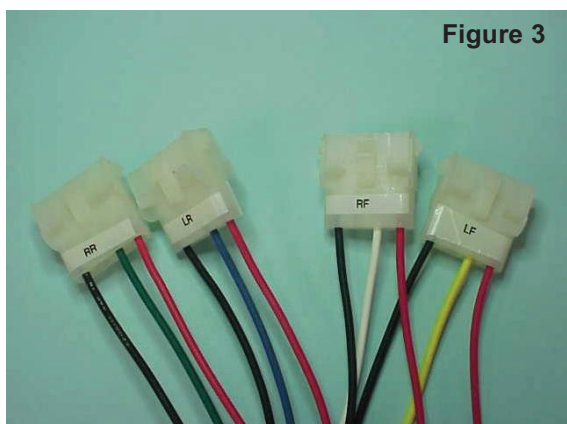

Figure 3

3. The sensor harness has 4 connectors, one for each jack leg (*see figure 3*).

The red and black wire power the sensor.

The color wire is used as the "signal" wire.



1217 E. 7th Street  
Mishawaka, IN 46544

[www.powergearus.com](http://www.powergearus.com)



Figure 4



4. A single 6 pin connector attaches to the control (*see figure 4*).

5. At attached to the Power Distribution harness which attaches to the jack leveling leg, the blue wire is not used (*see figure 5*). The remaining wires are

Power Dist	-	Sensor Harness
Orange	-	Red
Yellow	-	Color
Green	-	Black

Figure 5

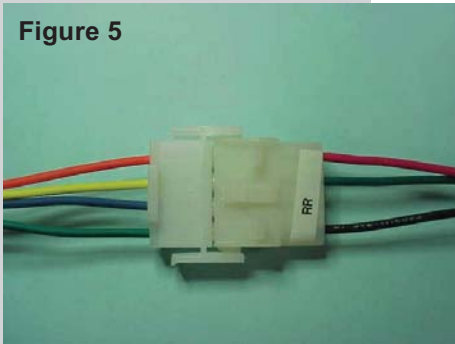

6. With the leveling touch pad turned ON, the sensor should be powered.

Check for voltage between the sensor connector RED and BLACK wire using a meter (*see figure 6*).

Probe from the back of the sensor harness. Red probe on RED wire, Black probe on BLACK wire.

12v (or battery voltage) indicates that the sensor is powered and ON.

If no voltage, check harness for connection and damage

Check for voltage between the sensor connector RED and COLOR wire using a meter.

Figure 6



7. Probe from the back of the sensor harness. Red probe on RED wire, Black probe on COLOR wire (*see figure 7*).

12v (or battery voltage) indicates that the sensor is triggered by the magnet.

The jack leg should be either fully retracted or extended positioning the magnet under the sensor

8. Check for voltage between the sensor connector RED and COLOR wire using a meter (*see figure 8*).

Probe from the back of the sensor harness. Red probe on RED wire, Black probe on COLOR wire.

If the jack leg magnet is not positioned under the sensor, is missing, or the sensor is not working, there will be no voltage.

Figure 7



Figure 8



1217 E. 7th Street  
Mishawaka, IN 46544

[www.powergearus.com](http://www.powergearus.com)