



### In This Issue

About This Newsletter	2
President's Message	2
Whom to Contact	2
Dutch Treat Rally	3
Drinkwater to Be MC	3
Great Seminars Planned	3
Tips for Better Photos	3
Presentation Planned	4
Calling All Duffers	4
WiFi and Computer	4
Coach Care RV Service	4
55 Alive - Learn and Save	4
Begin Planning Early	4
Map for York Rally	5
Schedule of Rallies	6
Sunshine Corner	6
National Board/Chapters	7
Founders' Forum	8
Call for DOAI Nominations	8
Orange Blossom Report	8
Orange Blossom Photos	9
Another Big Step for DOAI	10
Region News	
Northeast	11
Friendship Festival Rally	11
Chapter News	
Discovery Texans	12
Dixie Travelers	13
Heartland Discoveries	13
Mason-Dixon Discoveries	13
Midwest Discoverers	13
Northwest Adventurers	14
Texas Disco Road Runners	14
Feeding the RV'er	14
More Orange Blossom Pix	14
Diesel Battery Control Center	15
Gas Can Safety	16
Hints and Tips	16
One Man's Life	17
Safety Tips for RV'ers	18
Welcome, New Members	18
From Then to Now	19
Friendship Festival Form	20
Sale Page for Members	21
2005 National Rally Form	22
Editor's Ramblings	23
Membership Form	23



**LOOKING FORWARD:** More national rally news, more helpful articles, and more!

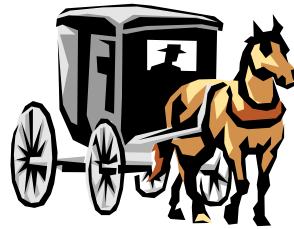



## Dutch Treat Rally

2005 National Rally at the  
York EXPO Center, Fairgrounds  
York, Pennsylvania - August 9-13, 2005

**Register soon for this SUPER rally!**  
**Super? Yep, super! Catch these highlights . . .**

- 

☞ The **DOCKENSPIELERS** will open the rally with typical Pennsylvania Dutch music as we enjoy a **DUTCH BEER FEST**, followed by a **PICNIC** of Pennsylvania Dutch food. If you aren't feeling like a Penn Dutchman by that time, you'll be treated to some **PENNSYLVANIA POLKAS!** You can watch, but we're betting you'll want to join in with the White Rose Polka Club to give it a try.
- 

☞ Have **YOUR PICTURE** taken with your significant other on opening night, then take time to view it to decide if you'd like to have a copy.
- ☞ We're planning an **ICE CREAM SOCIAL**, where we'll actually socialize while we make our own sundaes and eat them!
- 

☞ At the **RED HAT SOCIAL**, you ladies will get to see the movie, *Calendar Girls*, and may, if you're lucky, get to meet **Miss Latrina** and hear her poem about her red hat.
- ☞ We'll raffle a **HOMEMADE, HAND-TIED QUILT THROW** made from the lovely table fabrics used at the Sedalia national rally. All proceeds will benefit a local women's shelter.
- 

☞ **CONTINENTAL BREAKFAST** will be served each morning.
- ☞ The **first 35 people** to sign up for the **55 ALIVE DRIVING COURSE** will be the only ones to get a five percent reduction in auto insurance. The cost is \$10 for materials, class limited to 35, and course takes two four-hour sessions. This course is so valuable, it's worth taking it even if you didn't get the insurance reduction.
- ☞ **MORE RALLY INFO** on pages 3-4, and see **Registration Form** on page 22!

**About This Newsletter**

**Discovery EXPRESS** is published four times annually. **Deadline** for copy is the 20th of the last month in each quarter: March, June, September, and December. The editor can sometimes accommodate late submissions if advance notice is given.

**Member addresses and telephone numbers** published in this newsletter are for members' personal use only.

**Toll-free numbers** for officers and chairmen are to be used **only** for DOAI business, and then wisely, since it is costly for DOAI.

**Members** are encouraged to send in articles, tips, and even questions and/or comments in the form of *Letters to the Editor* (we'll make every effort to get the answers).

**Material** for the newsletter may be sent via e-mail or U.S. Post Office. Photos are welcome, and if sent via e-mail should be in either .jpg or .bmp format. Photos sent by regular mail will be scanned and returned unharmed to contributors.

**Discovery EXPRESS Editor**

Nina Lee Soltwedel  
4736 Harwich St.  
Boulder, CO 80301-4217  
888.786.2962  
soltwedel45@hotmail.com

**Please notify us when your address changes!** Notify the DOAI membership director as soon as your new address is known. Newsletters cost 75¢ to mail; every returned newsletter costs us 83¢, and another 83¢ to mail it to the new address...a total of \$2.41.

**Membership Director**

Portia Williams  
P. O. Box 95  
St. George, UT 84771-0095  
888.594.6818  
rgwilliams@sisna.com

**DOAI Website**

[www.discoveryowners.com](http://www.discoveryowners.com)

**DOAI eGroup**

[www.groups.yahoo.com](http://www.groups.yahoo.com)

**President's Message**

by Phil Yovino

**H**ello again, D owners! We're off to a good start for 2005 – the Florida Gators put on another super region rally at Lazydays with outstanding entertainment and, as always, good food. Mother Nature took care of the weather and from what I saw, everyone enjoyed the rally. Special thanks go to all the members of the Florida Gators chapter and to Pete and Alice Pizzano for the extra effort in putting together another great outing for our Discovery owners.



At the national rally in Sedalia, Missouri, last October, your board of directors voted to develop a brochure about DOAI, a one-page fold-up, to inform non-members about DOAI ... a color promotional brochure that we can hand out to D owners wherever we meet. Don Fuller, vice president of development, and Nina Soltwedel, our editor, took on this project, and it looks good so far. We hope to have it available to all members and in dealers' hands soon.

As you know, we have an AED defibrillator. As of the Sedalia rally we have 40 members certified, but we need to cover all our chapters. Therefore, I'm asking all our chapter presidents to have as many members as possible certified in CPR and AED so we can keep our Zoll defibrillator moving to as many rallies and campouts as possible. We pray we won't have to put it to use, but having it with us is peace of mind.

The election of DOAI officers is at the end of this year. Now is the time to be thinking about who you want to be an officer. Bob Baugh, our past president, will head the nominating committee. As I have said, this is your time to make a choice.

At the Lazydays rally, your board was really busy. We held three board meetings with great results. Don Fuller was able to secure enough sponsors to cover the cost of giving our *Discovery EXPRESS* a full-color cover. Thanks to Don and our editor, Nina Soltwedel, for making this possible.

Also George Weart of Fleetwood took part in a special meeting between our board and Fleetwood to put into action an advisory council. This council will work directly with Fleetwood service personal to help resolve problems. Contact your region vice president for the necessary forms and information. This is a giant step forward for DOAI and Fleetwood. Members will be able to request help when they have exhausted all other avenues. As you read your *Discovery EXPRESS*, the advisory council is working. Fleetwood has already helped several members with their problems, with positive comments toward Fleetwood.

I have appointed Portia Williams as our membership director. Portia and MaryAnn are presently transferring all necessary data. This is an important part of DOAI. We are pleased to have Portia on board. MaryAnn has done an outstanding job, and we thank her for all the time she has put into the membership director's position.



Portia Williams

As we look forward to summer, D owners will have many rallies and campouts to attend. We should all be planning on the national rally in Pennsylvania this August. From all indications, this should be a great outing, with all the planning and chapter support that has been put forth. Many wonderful events have been planned and, of course, there are all kinds of sightseeing opportunities in the area. It will be a good time to make this rally a family affair ... bring the kids – they will love it.

Dot and I are looking forward to seeing all our friends and D owners at the national in Pennsylvania. Travel safely, and enjoy every day. ❖

**Whom to Contact****GENERAL INTEREST OR ACTION ITEMS**

Phil Yovino, DOAI President  
210 Fairfield St  
LaPorte, TX 77571-7331  
pdyo@pdq.net – 877.246.4271

**FLEETWOOD CUSTOMER SERVICE**

800.322.8216

**FREIGHTLINER CUSTOMER SERVICE**

800.385.4357

### More Dutch Treat Rally Information

- ☞ Several **craft classes** will be available.
- ☞ A **golf outing** is planned.
- ☞ **Tour** the Harley Davidson plant.
- ☞ Following Wednesday's typical York County August dinner, we'll transport you to White Rose Downs for a night of **horse racing** at the **Dutch Derby**. Bring your dollars, as you're sure to want a piece of the action. Who knows...you may even want to show off your equestrian skills as a jockey!
- ☞ **Factory service** will be available from several of our manufacturers.
- ☞ Numerous **seminars** and **round-table discussions** are planned, to give you an opportunity to learn more about your coach.
- ☞ **Tour** Pfaltzgraff factory.

- ☞ **Make new friends** while we play **progressive card bingo**.
- ☞ **Door prizes galore!**
- ☞ Final night **pictorial rally review** by Lavoie Photography.
- ☞ **The Amazing Amos** will keep us in stitches as he tell us of the Amish lifestyle, following our **Pennsylvania Farewell Dinner**.
- ☞ **Sunday, August 7**, is the earliest day you may arrive.

The *Dutch Treat Rally* truly embraces the DOAI motto, "Spirit of Friendship," upon which the organization was founded. Three chapters: Nor'easters, Midwest Discoverers, and Mason-Dixon Discoverys, have joined together in that spirit to put together what promises to be a great rally. Read more details of several of the foregoing items elsewhere in this issue! ❖



### Drinkwater to Be Master of Ceremonies

**D**ave Drinkwater has agreed to serve as master of ceremonies at the DOAI 2005 national rally, *Dutch Treat Rally*, in York, Pennsylvania, August 9-13.

Dave and his wife, Diane, have been DOAI members for five years. They have three grown children.

The Drinkwaters are charter members of three DOAI chapters: Nor'easters 2002, Midwest Discoverers 2003, and Heartland Discoverys 2004. So, Dave is a great choice to speak for the group.

Dave has made the centerpieces for the *Dutch Treat Rally*. You will want to be one of the lucky winners of a centerpiece, to take home with you after the rally.



Photo by Rex Lavoie

Dave is a retired pipefitter, currently living in Ohio when not traveling in his Discovery. The Drinkwaters have previously lived in Connecticut, Massachusetts, and Maine.

Dave is a great person to be with on the road, as he is very knowledgeable about just about everything that can go wrong. ❖

### Great Seminars Planned for Rally

**T**he upcoming national rally looks to be a fun-filled and educational rally. Here is a list of the planned seminars. Watch for updates in the next issue of this newsletter.

- ✓ Operation and maintenance seminars by Fleetwood, Freightliner, Caterpillar, Cummins, Allison, Onan, and Norcold.
- ✓ *55 Alive* Safe Driving by AARP
- ✓ Stop! Please! - Auxiliary braking systems
- ✓ Are You Headed to a Fire? - Fire safety by Mac McCoy
- ✓ Thanks Tanks - Products for your holding tanks
- ✓ When It Really Matters - Sky Med is there
- ✓ WiFi Connectivity - Bring your laptop
- ✓ Computer Security - It's not safe in cyberspace
- ✓ Eco Quest - Technology for healthy living
- ✓ Crafts by Ladybug Linda
- ✓ Tips to Better Photos - Rex and Peg Lavoie
- ✓ Weight and Tire Safety - RVSEFF
- ✓ Food Never Tasted Better - Convection/microwave cooking
- ✓ What Your Daddy Never Told You About Power - The 12-volt side of life
- ✓ I Do It My Way - The Discovery owner's technical roundtable ❖

### Tips for Better Photos

**F**or the first time at a DOAI national rally, Peg and Rex Lavoie will present a photography seminar aimed at helping the photo hobbyist get better results from film and digital cameras alike.

Touching on basics that can help everyone make improved images, including travel photos, nature photography, family pictures, and special memories, the Lavoies will tap over 40 years of experience as professional photographers. They will share tips on composition, lighting, camera functions, lens and

film selection, and other subjects. They will touch on the use of computer programs for the digital photographer. Using examples of typical photos, the Lavoies will show a variety of ways to look at the same subject.

Rex is recognized as a master of photography and electronic imaging by the Professional Photographers of America. Both Rex and Peg have also received the degree of photographic draftsman from the PPA, and have taught amateur and professional photography courses throughout the U.S. ❖

### **Presentation Planned at York Rally**

A special visual recap presentation is being planned as part of the entertainment on the last evening of the York national rally this coming August.

The goal is to include everyone attending the rally at least once in the show. To kick off the event, during the opening night German Fest picnic, everyone will be professionally photographed at no charge or obligation.

Throughout the rally events, seminars, parties, demonstrations, and trade show, photographers will capture candid images of the fun to mix with the portraits from the first night.

The presentation will make for a great way to relive and recap the fun, friendship, and activities from the Dutch Treat Rally in York.

To be included in the show, be sure to have your portrait taken on the first night and join in on the fun all through the rally!

Portraits will be available for purchase as a memory of the fun we have when we get together. ❖

### **Calling All Discovery Duffers!**

If you know the difference between a slice and a hook (and it's not related to pizza and fish), then this article is just for you. While attending the Dutch Treat Rally, come out and join fellow Discovery owners for a morning on the links at beautiful Briarwood Golf Club in York, Pennsylvania.

Also, if you are one of those people for whom the distant yell of "Fore!" does not cause a stir deep within your bowels, then think of this as a great time to enjoy a leisurely stroll with wonderful companions in beautiful surroundings, punctuated by frequent opportunities to thoroughly embarrass yourself.

Either way, you are participating and we want participants! Please register now by contacting Alan Richie by phone (856.467.3421) or e-mail ([alanandarlene1@comcast.net](mailto:alanandarlene1@comcast.net)). The outing is scheduled for Thursday morning, August 11. ❖

### **WiFi and Computer Seminars at the Rally**

There are two presentations planned to cover Internet connectivity and computer security at the Dutch Treat Rally.

We expect to have WiFi coverage within the seminar building. You need to have either built-in WiFi capability or a wireless network adapter to use the service. If your computer does not already have an adapter, you may want to purchase one compatible with at least the 802.11g standards (for example, the Linksys WPC54G or D-Link DWL-G630 or similar).

Most electronic stores carry network adapters. Since computers have different requirements, please check with the computer manufacturer and/or the sales/service department of the store where you purchase the adapter to ensure it is compatible with your system.

The WiFi seminar is scheduled for late afternoon on arrival day. Bring your laptop. Someone will help with setup, if needed. ❖

### **Coach Care RV Service at Dutch Treat Rally**

You may have a few technical problems that you simply have not had time to address. At this year's national rally, Coach Care™ technicians and parts specialist will be there to address bumper-to-bumper problems. Coach Care is an initiative by Onan, Cummins, and Cummins distributors to provide quality RV service.

Whatever your maintenance concern – from the chassis to the engine to major appliances and Onan generators – stop by the Coach Care vendor booth to schedule a service call.

When you are on the road, each Coach Care facility offers 24-hour emergency service, seven days a week, and is committed to making RV maintenance and repair a pleasant experience. Included with each visit is complimentary overnight parking and a comfortable customer lounge, equipped with TVs and Internet access for added convenience.

For more information or to locate the nearest Coach Care service provided, call 800.888.ONAN, or visit [www.funroads.com/service](http://www.funroads.com/service). ❖

### **55 Alive – Learn and Save**

Take the AARP-sponsored safe driving course at the Dutch Treat Rally and save five percent on your RV insurance.

This eight-hour classroom course is geared to us mature drivers. It includes a review of driving laws, how to drive defensively, what to do about aggressive drivers, and adjustments to driving habits to account for changes in vision, hearing, and reflexes.

The course is scheduled for Thursday afternoon and Friday morning at a cost of \$10 per person. To receive the insurance discount, each person on your policy must attend. No tests!

To register, please contact our seminar coordinator, Marshall Godwin via e-mail ([godwin.marshall@grayhawksystems.com](mailto:godwin.marshall@grayhawksystems.com)) or via phone (540.379.6767). There is a limit on both the minimum and maximum number of attendees, so register early. ❖

### **Begin Planning Early for York**

If you have Internet access, you might want to start planning now for your trip to the Dutch Treat Rally. Go online to [www.yorkpa.org](http://www.yorkpa.org) and sign up to receive their free visitor's guide and calendar of events.

This handy guide lists all the wonderful places to visit, tours to take, sights to see, and events to experience either before or after the rally, throughout the York metropolitan area.

It also lists campgrounds, restaurants, and shopping opportunities galore. There are more factory outlets in the area than you can "shake a stick at."

Probably one of the best nearby tours to take is Gettysburg. The town is filled with history, good restaurants, and the battlefield itself is a trip back in time. Bring your camera and your appreciation for our country's history, and you'll never forget the experience. Stand in the spot where Lincoln delivered his Gettysburg speech! Before you leave the area, take time to tour the Eisenhower farm for a peek at one of our most popular president's home. ❖

**How to Get to York Expo Center for National Rally**

General overview of the York metropolitan area

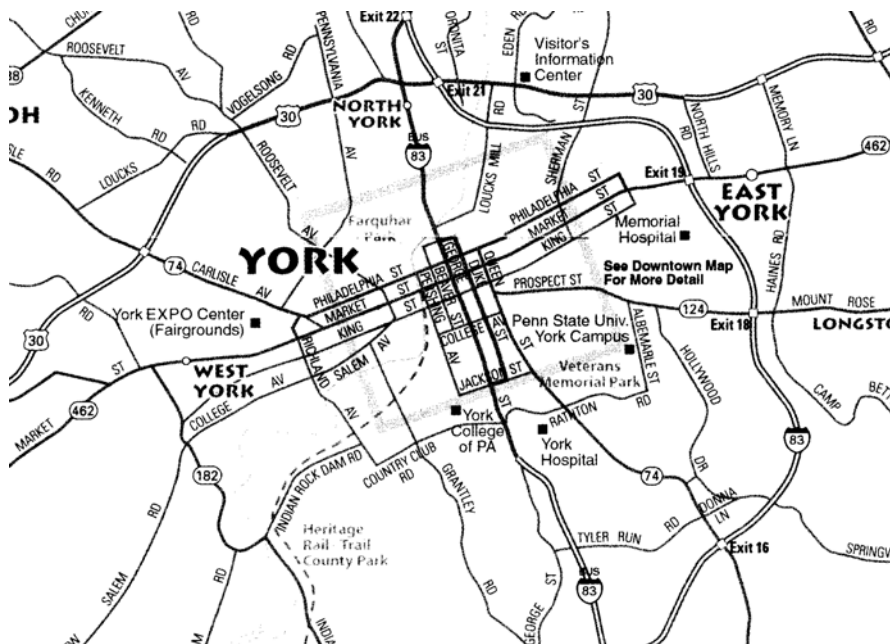

The street address of the York EXPO Center at the Fairgrounds is 334 West Carlisle Avenue. However, we will have all coaches enter Gate 6, which is on Highland Avenue. Therefore, follow these directions (and for additional help, see the close-up map below):

From the south: Take I-83 north to Exit 15 (Old Exit 5) (S. George St. Business 83). Turn left at the **second** traffic light (Country Club Rd.). Follow Country Club to Richland Ave. Turn right on Richland to Market St. Turn left on Market to Highland Ave. Turn right on Highland to Gate 6.

From the north: Take I-83 to Exit 22 (Old Exit 10) (N. George St.). At the second traffic light, take Rte. 30 west to the Carlisle Ave. exit. Turn left on Carlisle (Rte. 74) to Highland Ave. Turn right on Highland to Gate 6.

From the east: Take Rte. 30 west to Carlisle Ave. exit. Turn left on Carlisle (Rte. 74) to Highland Ave. Turn right on Highland to Gate 6.

From the west: Take Rte. 42 (W. Market St.) from Rte. 30. Follow Market to Highland Ave. Turn left on Highland to Gate 6.

From the northwest: Take Rte. 74 (Carlisle Ave.) to Highland Ave. Turn right on Highland to Gate 6.



**Schedule of Rallies****APRIL 2005 –**

4-15 Southwest Texas Rolling Rally, open to all Texas and Louisiana chapters members

28 Mid-South Roadrunners, Wilson, NC

29- May 1 Mason-Dixon Discoverys, Colonial KOA, Williamsburg, VA

**MAY 2005 –**

1-8 Discovery Pioneers, Goulding's RV Resort, Monument Valley, UT, and Riverside Oasis RV Park, Moab, UT

2-8 Florida Discovery Rolling Gators, Jolly Roger RV Park, Grassy Key, FL

12-15 Midwest Discoverers, Pioneer Park, Somerset, PA

13-15 Louisiana Mudbugs, Lake Bruin State Park, St. Joseph, LA

20-23 Northeast Region mini-rally, Somerset, PA

19-21 Dixie Travelers, Island Retreat RV Park, Gulf Shores, AL

19-21 Discovery Texans, Fredericksburg RV Park, Fredericksburg, TX

**JUNE 2005 –**

14-17 Texas Disco Road Runners, Sunset Point RV Park, Marble Falls, TX

23-25 Northwest Adventurers, McCall RV Park, McCall, ID

23-26 Heartland Discoverys, Mason County Fairgrounds, Ludington, MI

**AUGUST 2005 –**

9-13 **National Rally, Dutch Treat Rally, York EXPO Center, Fairgrounds, York, PA**



18-21 Florida Discovery Rolling Gators, Grandfather Mountain RV Park, Boone, NC

**SEPTEMBER 2005 –**

2-4 Discovery Pioneers, Elk Meadows RV Park, Estes Park, CO

8-11 Mid-South Roadrunners and Mason-Dixon Discoverys, Old Morganton Festival Days, Morganton, NC

15-17 Discovery Texans, Lazy Longhorn, Victoria, TX

22-24 Louisiana Mudbugs, Lakeside RV Park, Livingston, LA

T/B/A Dixie Travelers, Hollywood Casino RV Park, Tunica, MS

**NOVEMBER 2005 –**

4-6 Texas Disco Road Runners, Canton Trade Days, Staway RV Park, Murchison, TX

11-13 Louisiana Mudbugs, North Toledo Bend State Park, Zwolle, LA

17-19 Discovery Texans, I-35 RV Park, Elm Mott (Waco area), TX

T/B/A Mid-South Roadrunners, New Orleans, LA

**DECEMBER 2005 –**

1-4 Texas Disco Road Runners, Galveston, TX, park to be announced

**JANUARY 2006 –**

26-31 Southeast Region Rally, *Tri-Chapter Friendship Festival*, Lazydays Rally Park, Seffner, FL

**OCTOBER 2006 –**

8-14 **National Rally, Discover the Alamo, Blazing Star RV Resort, San Antonio, TX**



2007 **National Rally, Southwest Region**

2008 **National Rally, Southeast Region**

2009 **National Rally, Northwest Region**

Please send your rally schedule to the editor for inclusion in the next issue (**deadline June 20**). Thanks! ❖

**Sunshine Corner**

**P**lease continue to let the editor know of those DOAI members who need our prayers and best wishes. This time we mention specifically . . .

► Leon Sikes (Texas). Leon is recovering from a hernia operation and now faces removal of a cataract from his left eye

► Ed Koch (Indiana). Ed has been brought home from the

hospital, and his condition is deteriorating rapidly. Hospice is assisting; Ed is very weak and spends most of his time sleeping.

► Jackie Quinn (Texas). One of Jackie's bypasses came apart and a stent has been put into another vein. ❖

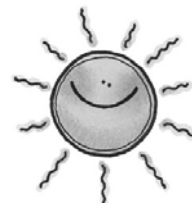

**National Board of Directors****President**

Phil Yovino, 210 Fairfield St, LaPorte  
TX 77571-7331; 877.246.4271;  
*pdyo@pdq.net*

**Executive Vice President**

Tom Fields, 1231 Huisache Ave, Apt  
1404, New Braunfels TX 78130-5791;  
877.238.6955; *thomfiel@earthlink.net*

**Secretary**

Joyce Bednarczyk, 137 Rainbow Dr,  
PMB 3769, Livingston TX 77399-1037;  
877.851.9874; *bedchk@peoplepc.com*

**Treasurer**

Mac McIlvaine, 1370 Parkside Dr,  
Zwolle LA 71486-4315; 877.245.9661;  
*macsworld@juno.com*

**Rally Master**

Pete Pizzano, 4712 Coachmen Rd, New  
Port Richey FL 34655-1501;  
877.238.6953;  
*alice.pizzano@verizon.net*

**Vice President/Development**

Don Fuller, 102 Rainbow Dr, #127,  
Livingston TX 77399-1002;  
877.246.4516; *wdfuller@aol.com*

**Past President**

Bob Baugh, 123 Applecreek Ln,  
Richmond KY 40475-9154;  
877.238.6952; *rcbaugh@chapel.us*

**REGION VICE PRESIDENTS:****North Central**

(IL, IN, IA, KS, MI, MN, MO, NE,  
ND, SD, WI)  
Dick Snyder, 411 Alexander Dr,  
Seymour IN 47274-8633; 877.282.0779;  
*snyderflys@comcast.net*

**Northeast**

(CT, ME, MA, NH, NJ, NY, OH, PA,  
RI, VT, ON, QC)  
John Baker, 399 Tri Hill Rd, York PA;  
17403-3854; 877.282.0776;  
*jpdsconvry@yahoo.com*

**Northwest**

(AK, CO, ID, MT, OR, UT, WA, WY,  
AB, BC, MB, SK)  
Jerry Woods, PO Box 1284, Maple  
Valley WA 98038-1284; 877.238.7095;  
*jerry@woodsfamily.ws*

**South Central**

(AR, LA, OK, TX)  
Garry Shirey, 2450 Williams Lakeshore,  
Kingsland TX 78639-4077;  
877.245.9654; *garryts@tstar.net*

**Southeast**

(AL, DE, FL, GA, KY, MD, MS, NC,  
SC, TN, VA, WV)  
Jim Devine, 25911 CR 49, Loxley AL  
36551-6413; 888.594.6819;  
*jimd@one800.net* or  
*f195810@earthlink.net*

**Southwest**

(AZ, CA, HI, NV, NM)  
Gerald Embry, 14572 Mesa St,  
Hesperia, CA 92345-2242;  
877.238.6954; *jmembry36@uia.net*

**DOAI Chapters and Presidents****Arizona Discovery Owners (AZ)**

Barbara Klusman, 10040 E. Ranch Gate Rd, Scottsdale AZ 85255-  
2306; 480.585.5599; cell 602.549.5590; *klusman@msn.com*

**California Goodtimers (CA)****Discovery Pioneers (CO, KS, NE, NM, UT, WY)**

Joyce Wiechman, PO Box 618, Scott City KS 67871-0618;  
620.872.3238 Kan./480.380.4717 Ariz.; *joycew30@aol.com*

**Discovery Texans (TX)**

Tom Fields, 1231 Huisache Ave, Apt 1404, New Braunfels TX  
78130-5791; cell 210.659.3886; *thomfiel@earthlink.net*

**Dixie Travelers (AL, MS, GA, FL)**

Howard Taylor, 8047 Ansley Trace, Montgomery AL 36117-8218;  
334.356.9052; cell 334.318.5552; *httaylor7@wmconnect.com*

**Florida Discovery Rolling Gators (FL)**

Tom Ebbert, PO Box 1134, Tavernier FL 33070-1134;  
305.852.9762; cell 305.393.1215; *quiltz4u@bellsouth.net*

**Heartland Discoverys (IL, IN, IA, KS, MI, MN, MO, NE, ND, SD, WI)**

Elfers Marzahl, 3905 Lake St, Burlington WI 53105-7722;  
262.763.6741; *elfers@pngusa.net*

**Louisiana Mudbugs (LA)**

Carolyn Barnes, 715 Stable Rd, Ruston LA 71270-3069;  
318.251.2568; *crb39@cox-internet.com*

**Mason-Dixon Discoverys (DE, MD, NJ, NC, PA, VA, WV)**

Dick Smith, 3000 Old Mountain Rd S, Joppa MD 21085-2910;  
410.612.9732; cell 410.937.2759; *poppop4171@msn.com*

**Mid-South Roadrunners (AL, FL, GA, KY, MO, NC, SC, TN, VA, WV)**

Ray Easter, 2724 Suffolk St, Kingsport TN 37660-3806;  
423.288.5274; *rayeaster@charter.net*

**Midwest Discoverers (OH, PA, IN, KY)**

John Wimer, PO Box 42, Hammondsville OH 43930-0042;  
330.532.3031; *john.wimer@att.net*

**Nor'easters (CT, ME, MA, NH, NJ, NY, OH, PA, RI, VT, QC, ON)**

Bob Giordano, 3277 Hemlock Farms, Lords Valley PA 18428-9114;  
570.775.1595 Penn./970.468.2515 Colo.; *pa1co2rv3@yahoo.com*

**Northwest Adventurers (AK, ID, MT, WA, AB, BC, MB, SK)**

Ken Swain, 2708 224th Ave NE, Sammamish WA 98074-6409;  
425.802.3240; *eagle747@earthlink.net*

**Texas Disco Road Runners (TX)**

Garry Shirey, 2540 Williams Lakeshore Dr, Kingsland TX 78639-  
4077; 325.388.4746; *garryts@tstar.net*

### Founders' Forum *by Jim and Dorothy Devine*



**M**aryAnn Crowell, the current membership director for our association, is reluctantly stepping down. She now has a full time position and does not have the time necessary to devote to the many duties of the membership director.

MaryAnn is such a great people person and is one of our association's key volunteers. She has been the first person to come into contact with many of our members, and is a great good will ambassador for the club.

At the Pueblo, Colorado, rally in May 2001, I became aware of MaryAnn's willingness to serve as membership director. Some of you may remember that Sharon Ayer was, at that time, the membership director and indicated she planned to relinquish the job at the end of 2001.

That fall, after the Urbana rally, MaryAnn was appointed to the position. Very few people would take on such a difficult task, and fewer yet would bring as much energy and enthusiasm as she has. Don, MaryAnn's



MaryAnn Crowell

husband, went out and bought her a new computer! I know they were planning on such a move, but with this new assignment, Don bought her a more powerful one (you can tell Don is no dummy...he knows how to stay on MaryAnn's good side!).

MaryAnn treated this new assignment as a pioneer job. She totally recreated the job description, creating for the board new reports, charts, and graphs. Much of what she came up with some of us didn't know could be done. She has done a fantastic job.

She added information and enrollment forms for chapters to the new members packets; she set up tracking of chapter memberships in the master database, and added CPR and AED certification dates, as well as tracking member attendance at each region and national rally.

MaryAnn and Don joined DOAI in April 1999, one year after it was formed. They are charter members of the Texas Disco Roadrunners chapter, and MaryAnn was elected to serve on the chapter's first board of directors.

MaryAnn holds the distinction of being our longest-serving membership director. She has done an extraordinary job that is so important to DOAI. All of us owe her a hug to let her know how much we appreciate her. You can reach MaryAnn at [relxn1@aol.com](mailto:relxn1@aol.com). ❖

### Call for DOAI Nominations

*by Bob Baugh*

**P**lease remember that the DOAI elections are to held later this year.

Currently the nominating committee is soliciting names for all offices of our association: President, Executive Vice President, Vice President of Development, Secretary, Treasurer, and all region vice presidents. In order to accomplish this, we are dependant upon the membership to submit nominations.

As past president, I currently serve as chairman of the nominating committee. If **you** would like to serve as an officer



of DOAI, or **know** of someone whom you believe would make a good officer, please let me know ([rbaugh@chapel.us](mailto:rbaugh@chapel.us)).

There are many good people in our organization whose services get missed because they are unintentionally overlooked. The committee will try hard, but it needs input from the membership for nominations.

To meet the deadlines set forth in the association's bylaws, nominations **must be received** by June 15, 2005. Please check with your nominees and get a commitment of their willingness to serve, then submit the names to the committee.

Let's all do our part in getting good people nominated for all the offices! ❖

### Orange Blossom Romp Report

*by Pete Pizzano*

**W**e were very pleased with the entertainment at this year's rally.

Attendees complimented us on the quality of the performers and gave them standing ovations (can we ask for anything more?). Upon command of the attendees ("Go ahead, Pizzano, top this year's rally"), Alice and I have already seen more than 30 entertainers perform in the weeks since the Romp ended. We believe the acts we have selected will "knock your socks off." They are top Branson-quality and prices.

Lupton's, the caterers, kept the bar open after the opening afternoon's entertainment ended. There was ample finger food including popcorn, and plenty of liquid for all (beer, wine, and soft drinks). The roast beef dinner, topped off by strawberry shortcake, was delicious. The second dinner of barbequed chicken and ribs was eye-appealing and succulent. Lupton's always has enough food for seconds.

Slightly less than 200 coaches were registered for the rally,



with more than one-half that number arriving early. RallyPark employees efficiently guided each coach to its assigned site.

Two sponsors, Fleetwood and Freightliner, sent representatives to the rally. Jayne Fairley gave an excellent welcome to the group, and George Weart, meeting with the board of directors, outlined a new public relations program. Ms. Fairley and Mr. Weart did a commendable job representing Fleetwood. Larry Doerr brought a Freightliner chassis and technicians. Mr. Doerr's seminar was informative and well attended. He and his staff were present the entire rally, answering questions and solving maintenance problems.

Seminars were conducted in a pleasant atmosphere and functioned smoothly. One problem we had was two of the seminar coordinators contracted flu and developed laryngitis. However, we received an apology from each, and gifts for our goodie bags and prizes.

Barney Alexander did his usual excellent job teaching driver safety and guiding students with on-the-road driving experience.

*Continued on page 9...*



**Orange Blossom Romp Report, continued**

Every year it is surprising to see how many talented people there are in DOAI. Crafts in all sizes and shapes were displayed at the flea market. The hours of labor and the minimal prices of items was noticeable by the volume of sales.

We have tried, through the years, to make gifts to coincide with the rally theme. This year the gals created beverage holders with orange yarn.

Thanks to the many sponsors who contributed prizes, we were able to award at least one gift to every coach. The major gifts ranged in value from \$150 to \$285. The winners of the 50/50 game won enough money to cover their rally expense and go out to dinner.

Alice and I, however, feel we won the best prize: your appreciation of our efforts and the many thank yous. ❖

**Orange Blossom Romp Photo Album**

*Photos by Bobby and Fay Williams*



RallyPark offers super sites



Alice and Pete Pizzano



Fay and Bobby Williams



Freightliner chassis drew interested Discovery owners



Jim Devine visiting at the welcome party



The first-timers get to help distribute door prizes.



The ice cream servers did a brisk business



The main meeting room is a great place for eating, gathering, chatting, fun, dancing...you name it



A trip to Seffner means a trip to Parkesdale Farms for scrumptious strawberry shortcakes!

### Another Big Step for DOAI

by Don Fuller

Your Discovery Owners Association board of directors and Fleetwood management have entered into an agreement, establishing an Advisory Group for the benefit of our members and Fleetwood Corporation.



Every member brings something to the table as a member of DOAI based on his/her life, job, and experiences. Our president, Phil Yovino, in his life prior to DOAI, worked for Cadillac as part of General Motors. One of his many positive experiences involved the establishment and operation of an advisory group which was intended to bridge gaps between the Cadillac owner and the Cadillac organization. That being a positive experience for Phil, and seeing similar needs between DOAI and Fleetwood, he began informal talks with Fleetwood management. The concept was received very positively by Fleetwood management and a draft proposal for the establishment of the Discovery Owners Advisory Group was prepared.

At the Southeast Region rally at Lazydays last January, Phil called a special board meeting at which George Weart, Fleetwood national owner relations manager, and Phil presented the draft proposal to the board. Phil reviewed the proposed mission statement:

“The primary mission of the Discovery Owners Advisory Group will be to maintain open dialogue regarding the Discovery product and customer service to assure the Discovery product is meeting the expectations of owners and to support the members of DOAI.”

Executive Vice President Tom Fields reviewed the proposed structure of the Advisory Group:

“The Advisory Group shall consist of a designated national DOAI liaison (the Vice President of Development) and the region vice presidents of each of the six DOAI regions. The Advisory Group will maintain communication and provide information via the national DOAI liaison. The national DOAI liaison will have a direct and frequent contact with the product development/design and owner relations management staff at Fleetwood. During national or region DOAI rallies, the Advisory Group will meet with Fleetwood management to discuss issues of common interest to Fleetwood and DOAI. In addition, any issues that have not been previously discussed will be reviewed for resolution.”

The meeting proceeded with detailed discussions on various aspects of the advantages of the Advisory Group and George answered many questions about Fleetwood goals, philosophies, dealer service, customer satisfaction, and resolution of product problems.

The meeting was adjourned after one hour of discussions. Subsequent board discussions led to minor changes to the proposal presented earlier and approval of the establishment of the Advisory Group. As DOAI's vice president for development and thus the national DOAI liaison, Don Fuller undertook the task of developing a description of operations for the group so that each member of the group had clear direction

of how it will function. The basic operations will be as follows:

Problem reporting is intended to take place when other actions have failed or when satisfactory or unsatisfactory service has been provided (note that reporting of positive experiences is also desired). Members should have followed the following process to resolve their motorhome problem:

- \* Take the motor home to one or more dealers for problem resolution.
- \* Call Fleetwood Customer Service at 800.322.8216 to report an unresolved problem.
- \* If not satisfactorily resolved, call Customer Service and ask to speak to a Customer Service Supervisor.
- \* If not satisfactorily resolved, call Customer Service and ask to speak to a Customer Service Manager.

When a DOAI member has not been able to resolve the problem by following the above process, the member should contact his/her region vice president who will fill out an Owner Reporting Form. Acting as a member of the Discovery Owners Advisory Group, the region vice president will submit the form to the national DOAI liaison (the vice president for development). The liaison will coordinate the report with the board of directors, as necessary, and will then submit the form to Fleetwood owner relations management. The member will then be contacted directly by Fleetwood for resolution. The member will be asked to keep his/her region vice president informed as to action/resolution, etc. The region vice president will, in turn, keep the national DOAI liaison informed as to action/resolution. The national DOAI liaison will report results, as necessary, to the board of directors and the membership via the *Discovery EXPRESS*.



This process and the Owner Reporting Form are to be used to report unresolved motor home problems, for reporting problems experienced with dealers that members feel need to be resolved by Fleetwood management, or for positive action feedback.

Please note that this process is not intended to resolve problems by interjecting the Discovery Owners Advisory Group between a member and his/her dealer. In other words, if the member is unable to get satisfactory problem resolution with a dealer and/or by contacting Fleetwood customer service, then the Advisory Group will get involved and bring the issue to Fleetwood management for resolution.

We are sure we have not foreseen all pitfalls of this procedure nor do we presume that all problems can be resolved. However, we are confident that, given an opportunity to test the system and procedures, DOAI members and Fleetwood have the potential for many positive experiences in the future.

I am pleased to report that we have already had positive results from the close liaison established with Fleetwood management. During activities at the Lazydays rally, several common problems were brought to my attention via region vice presidents. The fact that the same problem had been reported by several members, I felt justified to verbally report the information to Fleetwood management. Within a few days

*Continued on page 11...*

### Another Big Step, continued

each member who reported the problem had either been directly contacted by an assigned customer service representative or a message had been left for subsequent contact. In each case the problem had already been analyzed, a solution developed, and the member had been given instructions as to how the solution would be resolved at a dealer or contracted service point. Since that initial action, I know of at least one other positive resolution of the same problem for another member and others are in progress. WOW! That is exactly how this is intended to work!

One other extension of the Advisory Council establishment has been a close relationship with an assigned customer service representative who is now monitoring the DOAI eGroup communications. He has reported to me that several situations that he felt were urgent or emergency have been resolved by direct e-mail contact with the eGroup member. Don't be surprised when you are contacted directly by this Fleetwood person after you have reported a symptom that trips his urgency trigger. This very conscientious person has other duties and does not have time to answer each and every

report, but emergency situations will always be a priority.

Folks, I don't know about you, but I am very excited about this new relationship with Fleetwood and the potential it has for all of us in the future. I think we all owe Phil a BIG THANK YOU for his grabbing the ball and getting this going. Also, we owe a BIG THANK YOU to George Weart, Fleetwood's national owner relations manager, for his leadership and very professional approach to assist in this venture.

One last note: please don't forget that this effort is not just for reporting problems. Let's make an effort use this reporting system to praise those dealers and service folks who deserve a pat on the back from the top folks at Fleetwood. ❖

*Don Fuller is a longtime member of DOAI and has served our organization in many capacities including editor of this newsletter, southwest region vice president, and currently as vice president for development. Don and Karen recently became full-timers and are enjoying their travels around our great country.*

### Region News

#### Northeast Region

by John Baker

The chapters from the Northeast Region gathered for wine and cheese at the Orange Blossom Romp at Lazydays in February. Old friendships were renewed and new ones blossomed. Planning for the *Dutch Treat Rally* in York, Pennsylvania was the main business discussed.

With the new Mason-Dixon Discoverys chapter overlapping into the Northeast Region, they've joined with the Nor'easters and Midwest Discoverers so that we now have

three chapters contributing their time and talents to make the national rally a real treat.

Dorie Baker, the rally master (or should I say, mistress?) is thrilled with all the help she has received from the three chapters. Working together has given all of us great friendship-forming as well as idea-sharing opportunities.

In the planning stages is a regional mini-rally near Somerset, Pennsylvania, May 20-23 so that the three chapters can finalize the plans for the national rally. Everybody is welcome to join us. For information, contact Jane Wimer (330.532.3031). ❖

### Tri-Chapter Friendship Festival by Pete Pizzano

On February 1, at the close of the 2005 Southeast Region rally, Dick Smith, Manuel Salter, Marshall Mauck (rally co-chairmen representing Mason-Dixon Discoverys, Mid-South Roadrunners, and Dixie Travelers chapters), and I met to begin planning for the 2006 region rally, *Tri-Chapter Friendship Festival*, scheduled for Thursday, January 26-Tuesday, January 31.

Researching previous years' statistics, we discovered that a large majority of rally attendees arrived one or two days early. This fact encouraged us to extend the rally one day, making it a six-day vacation with good food, entertainment, fun, education, and friendship. Ladies, the only meals you'll have to prepare are those meals you have while traveling to the rally. Of course, Friday night is a go-out-to-dinner night, isn't it?

The first major decision to make was how to fill the added day. A picnic! We traveled to Boggy Bottom, a perfect place for a picnic. Boggy has a large, cool, covered building with all the facilities – clean, open kitchen and BBQ pits to cook and serve hot dogs and hamburgers, provide condiments, and a

help-yourself soft drink fountain. There are games to be played, card tables, bean bag baseball, a putting green, or you can walk on a nature trail seeing Florida as did Ponce de Leon. If we are lucky, perhaps Ralph Lupton will give us a brief session on the history of the area surrounding Boggy Bottom.

Bill Hazel will have RV maintenance seminars in the classroom in the Lazydays sales building. Bill will try to schedule microwave/convection cooking during our rally. Barney Alexander and Jim Rhodes will teach RV driving safety and on-the-road driving, using a new 2006 Discovery. Jayne Fairley, a strong DOAI supporter and Fleetwood representative, will see that we have Fleetwood support and that we have many 2006 Discovery coaches to inspect and buy.

The addition of another day and the picnic will increase the 2006 rally fee. Lazydays' site fee has been increased by \$3 per night for 2006. Collectively, the extra day plus the site fee increase surpasses the total price of this year's rally. However, the rally chairmen, with the full cooperation of Lazydays' marketing department and RallyPark, worked out a program that is beneficial to DOAI: RallyPark

*Continued on page 12...*



### Tri-Chapter Festival, continued

has agreed to do all the rally registration, printing, contracting my approved entertainment, my approved dinner and caterer, and do all the arrangements for the Boggy Bottom picnic. This is a mutual first. Because RallyPark rates DOAI as among the best managed rallies held at RallyPark (a compliment to all), they have volunteered to perform these administrative tasks, providing a considerable financial savings to DOAI, and removing tasks done by chapter members.

The natural question is, what is the bottom line? Considering the increase in site fee, the additional day and the picnic, the increase amounts to only \$7 per day.

The three chapter rally chairmen and I are very pleased that the rally fee is \$210 or \$42 per day, which is less per day than other rallies. Not only is it less, but we are giving you more amenities.

Although not totally confirmed, we have a tentative program schedule for the *Friendship Festival*. The rally is a six-day, five-night rally, scheduled between Florida's Tampa RV Show and the Brooksville FMCA Rally.

The first day, Thursday, a welcome party is scheduled. The second day is a very active day: seminars, vendors, flea market, and an ice cream social. Saturday: seminars, vendors, roast beef dinner and the fabulous New Odyssey. Sunday: continental breakfast sponsored by the three chapters, and Boggy Bottom picnic. The final full rally day, Monday: seminars, vendors, fried chicken dinner and the Belairs.

The sponsors of the *Friendship Festival* are Lazydays, RallyPark, Fleetwood, Freightliner, and three Southeast Region chapters – Mason-Dixon Discoverys, Mid-South Roadrunners, and Dixie Travelers.

Breakfast is free every day, lunch is free every day with a self-serving soda fountain, tea, and coffee, and there's a newspaper delivered to your site. The amenities are numerous.

It is not too early to register for the *Friendship Festival*. A \$42/day vacation with quality entertainment is a bargain. The three chapters are pleased to offer this vacation package at such an affordable price. Have your credit card ready and call RallyPark and make your reservation. ❖

### Chapter News

#### Discovery Texans

by Elsie Sikes

**O**n January 20-22 at Red Oak Ranch RV Park, Hempstead, Texas, we held a reunion between current Discovery owner-members and those who have had to drop out because they no longer own a D. We had a great time with 34 rigs and two people who attended without their rig!

Hempstead became known as "Six Shooter Junction" back in the early 1900s because of a shoot-out in the county courthouse during a famous trial, where four people lay dead. As a personal aside, I was shown a spot by my father where he stood behind a pillar in the building while the shooting was going on when he was about 20 years old.

Liendo Plantation is nearby, where George Armstrong Custer was in charge of a Confederate prison camp and where Buffalo soldiers served.

While the 20th was arrival day, many arrived a day earlier. Early arrivals visited various places in the area and checked out local eateries.



Herb, Avis, Jackie, Della ...cooks extraordinaire!

The host team of Della and Jackie Quinn, and Avis and Herb Petersen, did a wonderful job planning and executing an old-fashioned hayride/wiener roast in the woods; games such as horseshoes, washer toss, beanbag baseball, and hula hoop competition; dinner of chicken-fried steak and all the fixings; genuine farm breakfasts of eggs, grits, sausage, and Texas toast, etc. All the meals were made from "scratch," and when the cooks were introduced to be thanked, they received a standing ovation.

Because of this rally's success, our chapter elected to have

a reunion rally every year in order to continue our friendships with great people who, for various reasons, were convinced to buy some other brand. One former member couple said they are ready to go trade their SOB for another Discovery so they can come back to our group on a permanent basis.



Early morning at Red Oak Ranch

On March 19-21 the chapter rallied at Whispering Pines, Tyler, Texas. Seventeen rigs attended and the 34 people shared the fun of fishing at the Sawyers' farm nearby, and taking in the Azalea Trail in Tyler, a Civil War re-enactment, craft show and other fun events. Jim Bednarczyk caught the first big catfish, but Sarah Hallem caught the largest.

As the fish were caught, they were stored in a live well at the pond, but someone goofed; when they went to retrieve the fish in order to prepare them for cooking, the fish had escaped! Fortunately, fish from earlier catches were provided from the freezer, and everyone was able to get filled to the brim with fried catfish.

As I am writing this, 11 of our members are on the first leg of a rolling rally with seven Mudbug members and eight Texas Disco Road Runners from the South Central Region. Jay Kenneson serves as rally master and has put together a great trip. Also joining us is Betty and Jerry Rabinkoff from Arizona. We have rendezvoused at Fort Clark, with three days here and then on to Sanderson, Presidio, Study Butte, Big Bend National Park, and McDonald Observatory. More about this rally in the next issue! ❖

Continued on page 13...

**Chapter News, continued****Dixie Travelers**

by Howard Taylor

With cold weather behind us and warm days ahead, the Dixie Travelers chapter members have plans for many miles of travel and fellowship.

We have 30+ members from Alabama, Mississippi, Tennessee, Georgia, and Florida. We welcome any Discovery owner to attend our rallies.

Ten members attended the Southeast Region rally in Seffner. We all enjoyed the rally and say thanks to the Florida Discovery Rolling Gators. Next year we will assist in the hosting responsibilities.

Our spring rally will be at Island Retreat RV Park, Gulf Shores, Alabama, May 19-21. Please make your reservations by May 1 (phone 251.967.1666; tollfree 866.974.9999; e-mail [islandretreat@gulftel.com](mailto:islandretreat@gulftel.com)). Hosts will be Taylors, Florences, Misenheimers, and possibly Gilliams.

Our fall rally will be at Hollywood Casino Hotel and RV Park, Tunica, Mississippi.

New members are welcome! For information call Howard and Audrey Taylor (home 334.356.9052; cell 334.318.5552; e-mail [htaylor7@wmconnect.com](mailto:htaylor7@wmconnect.com)).

**Heartland Discoverys**

by Elfers Marzahl

Hello, everyone! Those in our chapter who attended the *Orange Blossom Romp* had a great time. We were able to get better acquainted with each other. Our fairly new chapter has added new members; we now number 29 member coaches. That's pretty awesome for such a new chapter.

If you've never attended the Lazydays rally, let me fill you in on all the wonderful activities. During the day there were seminars teaching or reteaching many concepts on operating our Discovery motor homes. Evenings were set aside for socializing, entertainment, and delicious food.

Business-wise, Dick Snyder is guiding us in setting up chapter bylaws.

Debbie Finger has worked hard to set up our June rally in Ludington, Michigan. It looks to be a time to remember, and everyone is welcome. See the Winter 2005 issue for complete details (also available online at [www.discoveryowners.com](http://www.discoveryowners.com)). Debbie also adds some late-breaking news: The Scottville Clown Band Fun Fest and Patriotic Concert is scheduled for June 28. This is a must-see event, so you may want to stay several days longer after the chapter rally concludes.

Debbie also advises that a special discount is being offered to those who sail aboard the S.S. Badger to attend the rally. Again, see the DOAI website for details.

See you all in Ludington in June!

**Mason-Dixon Discoverys**

by Dick Smith

The Mason-Dixon Discoverys have had a great year. From our humble beginning with six couples last June, we have grown to 27 couples in just ten months. We look forward to continued growth in 2005. Our area covers seven states, and we have members in nine states!

Our next rally will be at Colonial KOA, Williamsburg, Virginia, April 29-May 1. Bob and Debi Fowlkes have a fun weekend planned, and there is so much to see and do in the Williamsburg area. Sign up and join us; contact Bob and Debi

at [bufowlkes@msn.com](mailto:bufowlkes@msn.com) (phone 757.713.1171). You will need a check for \$20, representing \$10 deposit on campsite and \$10 rally fee. We will try to schedule the balance of our year's rallies while there.

We are working on one for September with the Mid-South Roadrunners at the Old Morganton Festival Days, Morganton, North Carolina, September 8-11. The cost is \$20 per night for full hookups, and a \$15 rally fee. Rex Shuping, who is a member of both chapters, has done this before, and he assures me that it is a great festival with continuous entertainment, good food, good fellowship, and good RV sites. Now, what more could you ask for, for a really great rally?

Be sure to keep in mind and make plans for the DOAI national rally at the York EXPO Center, Fairgrounds, York, Pennsylvania, this coming August. This is another area that has so much to see and do. Dorie Baker is the rally master, and I promised her that we would provide her with a lot of help. So, when she calls, step up and volunteer to help in any way you can.

Our chapter, along with the Mid-South Roadrunners and the Dixie Travelers, have been asked to host the Southeast Region rally at Lazydays next year. We accepted, after much discussion, and are hard at work on plans. Pete Pizzano, who is a member of all our chapters, has agreed to once again be the rally master for this event. With all that we have planned, we decided to go to a six day/five night rally. We have some great surprises planned for you.

I know not everyone winters in Florida, but a two-week vacation about this time of year sure would help cure the depression brought on by a cold climate. You could go to this one, then travel right on to the FMCA Southeast Region Rally at Brooksville, Florida. That's what we do, and it sure makes for a couple of weeks of good times and good fellowship with RV'ers. I hope to see everyone at all these rallies.

**Midwest Discoverers**

Photo by Rex Lavoie



Midwest Discoverers members who attended the *Orange Blossom Romp* are shown here, left to right. Row 1: John Baker, Shirley Clarke, Lora Gibson, Jane Wimer, Sylvia Holmes, Sally Vedder, Diane Drinkwater, Mary Edens. Row 2: David Withey, Joanne Withey, Dorie Baker, Steve Clarke, David Gibson, John Wimer, Dick Holmes, Donald Vedder, David Drinkwater, Skip Edens, Jack Romeyk. Row 3: Cindy Merkt, Peggy Crisp, Loretta Schafer, Ginnie Burton, Nancy Gaylord. Row 4: Rex Lavoie, Peg Lavoie, Ron Merkt, Larry Crisp, Ray Schafer, Chuck Burton, Lenny Gaylord.



Dick Smith,  
chapter president

**Chapter News, continued****Northwest Adventurers**

by Ken Swain

The Northwest Adventurers chapter held a rally in California the second week of January. We assembled in various locations prior to the rally and met in Blythe for the Bluegrass Festival. We met at a pre-determined location and then drove into the grounds together. Six member couples attended, along with two guest couples. We dry camped on the infield of the fairgrounds only a short distance from one of the stages, so we could hear all the music and have shorter distance to walk.



Diane Allen, Neva Jardine, Fran Woods, Portia Williams, Betty Schmitt, Sylvia Swain

The days before the festival began on Friday were filled with golf, sightseeing, dinners out, "hand and foot" games, etc. We came in on Monday morning and left the following Monday. Lots of fun!

We all enjoyed the music and the jamming at night around the area. There was a potluck dinner one night, a trip to Blythe



Bob Williams, Ken Swain, Jerry Woods, Alton Schmitt, Ken Jardine, Repair Man

for another dinner, and a pie social another night.

Everyone involved had a great time, and we are looking forward to a repeat next year. All chapter members, of course, are invited, as well as guests from other chapters. ❖

**Texas Disco Road Runners**

by Garry Shirey

Texas Disco Road Runners have enjoyed two great rallies since the last newsletter. December 1-4 we were in Brenham and participated in their "Christmas Stroll." This is an annual event where the downtown businesses go all out with decorations, entertainment, and parades.

February took us to Waco. The majority of the group headed to Crawford, Texas, to have one of those famous hamburgers President Bush finds so good. Indeed, they are very good. Most importantly, our group of 20 appearing at the lunch hour without reservations did not seem to throw them. Some enjoyed the museums, while others went to the home and garden product show.

At press time, 29 couples are participating in a rolling rally through southwest Texas.

Our next rally will be at Sunset RV Park, Marble Falls, June 14-17. If interested in visiting with us, contact me, or Jay Kenneson, or Don Crowell for reservation information. ❖

**Feeding the RV'er**

by Nina Lee Soltwedel

This issue's recipe comes to us from Marion Becker. She shared it with me while we were visiting Marion and Harvey at their winter home in Yuma, Arizona. Marion says this is a great dish to take to a potluck.

**Strawberry or Raspberry Pretzel Salad**

1½ cups finely crushed pretzels

3 T. sugar

1½ sticks margarine

Crush pretzels. Mix sugar and margarine into pretzels until well blended. Pat into the bottom of a glass 9"x13" baking dish. Bake at 350° F for ten minutes. Cool completely before doing anything else.

Mix two 6 oz. packages strawberry or raspberry gelatin with 2 c. boiling water (to dissolve gelatin). Then add ½ c. cold water Stir these ingredients together and add two 10 oz. packages frozen strawberries or raspberries. Mix well and put in refrigerator, **but only until slushy.**

While waiting for the gelatin to get slushy, beat 6 oz. package cream cheese together with ¾ c. sugar

Fold in 4 oz. Cool Whip. Spread the gelatin mixture over the cream cheese layer and chill until firm. Best if made the day before and put clingy plastic wrap to cover. This serves 12 easily if serving individually, or more if scooped out as in a potluck. Note: Marion puts a dollop of Cool Whip on top and sticks in two pretzels vertically for a festive look. ❖

**More Orange Blossom Romp Memories**

Edna Pendergrass was awesome...



...the dancing was fine...



...and the fire safety seminar was super!



**Diesel Battery Control Center** by Terrence Mills

There is some confusion among Fleetwood owners as to the exact function of the Battery Control Center. Contradictory explanations abound and many of them have found their way onto Internet chat rooms and bulletin boards where the tendency is to accept them as fact. To set the record straight we will be examining the history and function of this important component.

The Battery Control Center (BCC) is the point of contact between the house and the chassis 12 volt systems. The BCC controls the Fleetwood devices and electrical loads when the ignition switch is turned. It connects and disconnects both the \*chassis and coach batteries from their loads (except the inverter); controls the fog lights; protects all of these circuits with fuses and breakers, and allows "paralleling" of the coach batteries and the chassis batteries for charging and emergency starting through a relay. The loads protected by fuse positions F17, F18, F19 and F23 are not controlled by the battery disconnect system.

The original BCC board, CB-300D Revision A, was produced in January 1994. Over the years RV Custom Products has revised their board a total of eight times in order to keep pace with the changing requirements of the industry. The changes were:

- ▶▶ Revision B in April 1994 added coach battery as a second power source
- ▶▶ Revision C in January 1997 incorporated several changes:
  - ▶ Monitors for overloads of charging relay
  - ▶ Charging of chassis battery from shore power
  - ▶ Inclusion of ignition relay on the board
- ▶▶ Revision D in July 1998 changed the fuse description on the electronic board
- ▶▶ Revision E in August 2001 was minor silk screening changes to the electronic board
- ▶▶ Revision F in October 2001 added transistors to automatically switch the chassis (and coach) battery

Green circuit board located inside the battery control center box ▶▶▶▶▶

*Editor's Note: This is the first in a series of helpful articles which will be shared with all DOAI members by Fleetwood and its knowledgeable staff. On behalf of DOAI, I extend thanks to Fleetwood and all its employees for their continued support.*

disconnects on when the ignition key is turned on and changed the battery disconnect fuse on position F19 to 5 amps

- ▶▶ Revision G in March 2002 added fuses P18 and F23, and minor silk screening changes
- ▶▶ Revision H in May 2003 changed F23 from 7.5 amps to 10 amps
- ▶▶ Revision J in October 2003 added D71 and D81, and upgraded F23 from 10 amps to 20 amps

**\*NOTE:** Some of the early Discovery motor homes may not start if the chassis battery disconnect is turned on to disconnect the battery. This is normal for these motor homes built at that time. Later on, Freightliner suggested body builders not disconnect their chassis electrical from the chassis battery because of the electronics in the system. Most likely, when you disconnect your chassis battery on your Discovery motor home, your vehicle will still start and this is normal. You are only disconnecting the Fleetwood electrical side of the system.

These changes are "backwards compatible" which means that a newer board may be used to replace an earlier board; however, older boards cannot be used in new coaches.

Current from different parts of the 12-volt system powers the different circuits in the BCC. The chassis battery energizes the fuses in positions F1 through F5 and position P15. These control the power seats, the step motor, the step switch and the LP leak detector. When the ignition switch is turned on, positions F6 through F13 are energized. These control the power mirrors, horn, leveling jacks, dash fan and fog lights. Positions F15 through F23 are energized by the auxiliary (coach) batteries

which power the LP leak detector (when the chassis battery is disconnected), the radio park/travel switch, the auxiliary start circuit, the isolator relay, the solar panel, luggage compartment lights, awning, the utility light and the battery disconnect relay.

Although most of us may not have the technical expertise needed to address the problems that can arise in the charging and emergency starting portion of the BCC, a ready supply of automotive fuses and a basic knowledge of the workings of this system will help in understanding the battery control system. ❖

*Terrence Mills has been with Fleetwood Motor Homes since July 2001 and has provided several articles to company publications. Terrence works in the Fleetwood Service side of the company.*

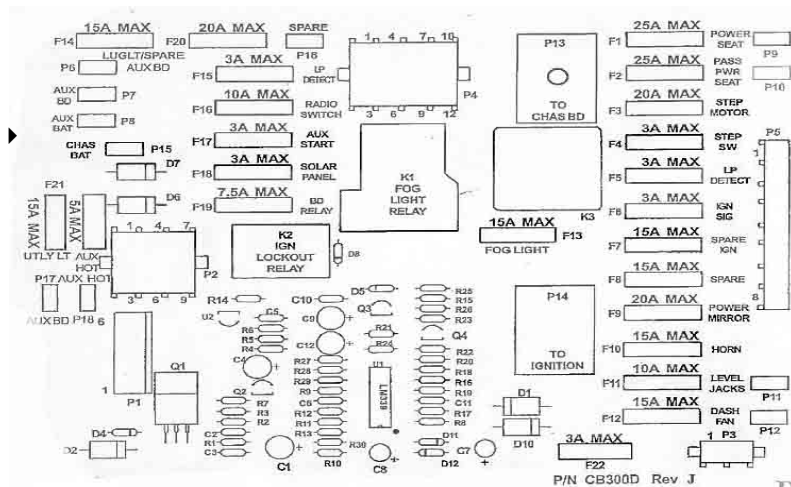

## Gas Can Safety Advisory

by Leo Everitt

Do you store your gas can like this . . . . .



. . . . .or like this?



I recently discovered that to store it like the top picture could be extremely dangerous, at least for the maker of my can sold at Wal-Mart among other places. These are manufactured by Blitz and called “ventless” or “self-venting.”

I had several weeks earlier purchased two new ventless cans for use with my snow blowers. I had filled a 2+ gallon can to the marked fill line at a local gas station, then took it home and used a fair amount to fill a Toro snow blower which I had just received back from being serviced. So, the actual volume remaining was well below the fill mark. It sat in my garage for several weeks without incident with the spout inverted into the can as I have always done in the past with other cans. The manufacturer’s label does show a picture of the spout like lower picture, which is labeled “Store Safely”. However, one can interpret this in several ways and I chose the wrong one, i.e., I did not realize it meant the spout can not be inverted into the can as shipped and sold.

On what is considered a warm day here in the mountains, i.e., above freezing, I opened the garage door and began to work on installing tire pressure monitors on my toad. The sun was shining well into the garage; enough so as to bathe the gas can in full sunlight. After some period of time I became aware of a fuel smell.

I first thought it was simply that I was working close to a John Deere snow blower and some gas vapor was leaking. However, the smell shortly became more intense and I looked across the garage to see a three-foot puddle of gas on the

floor and spreading. I called my daughter who lives down the street and asked her to rush me up a bag of cat litter from a supply she keeps on hand at all times. I removed the gas can from the garage and as soon as she arrived, we spread the litter and absorbed the gasoline.

I realized, after thinking about it for some time, that those well known laws (Charles/Boyles/etc.) were at work. As the sun warmed both the air in the can and the gasoline, expansion took place, forcing the gas up the spout and out. In previously designed cans, the lid on the spout was a tight fit, forcing the can structure to absorb the expansion. However, in this design the lid is a special design that allowed the fuel to escape.

I contacted both Wal-Mart and the manufacturer. Wal-Mart’s response was limited to simply saying they were referring it to their commercial department, which never responded. The manufacturer did respond to my several queries. Bottom line: they said they were in the process of releasing a new design cap and a new label that would clearly state not to store spout in can.

I responded that I felt the existing inventory should be re-labeled but got no response. My fear is that folks will do as I did and in the summer, when either ambient temperature rises or the sun sneaks in through a window and hits the gas can. Others will have same spillage, which could be fatal, especially in newer homes where gas water heaters are installed in the garage. In any case, I thought it worth exposing my mistake in the hope of preventing anyone else from doing likewise. ❖

**Editor’s Note:** At press time, Leo sent the following e-mail: “As a follow-up on my gas can story, I had to leave my cans in Park City when we moved. I went to Lowe’s and saw a new, unopened pack of them setting on the floor. I opened it to get one. The can has the new label which clearly shows **how to** and, just as importantly, **how not to** store if filled with gasoline. My daughter says the company probably calls it “Leo’s Label.” (very big grin) ❖

*Leo Everitt and his wife, Jackie, are longtime members of DOAI. They recently left the mountains of Utah and moved to South Carolina. Leo’s willingness to share his experiences and knowledge with all DOAI members is much appreciated.*

## Hints, Tips, and Suggestions

☞ Dan Fletcher shares this tip: “If your antennae or dish cables tap on your roof as you cruise down the road, cover them with PVC insulation. It will have to be attached (my plastic zip ties deteriorated). Use small wire or nylon cord.”

☞ Another from Dan: “I was told by Allison Transmission to keep the cruise control on, diesels only, while climbing moderate inclines. This will not damage the engine nor the transmission. This is not

recommended for gasoline engines, they said.”

☞ Bob Cook advises: “For those using Verizon, my friend Don Blake (owner of the Yahoo eGroup *internetbycellphone*) advises that you **do not** need Mobile Office and can therefore avoid the \$5/month charge. He says this option is mistakenly added on by unknowledgeable sales people.”

☞ Ladies: If you have the Discovery model with a sink in the bedroom, you’ve probably noticed that the

mirror in the cabinet door is only helpful if you’re six feet tall. Try adding mirror tiles to the wall directly behind the faucet (and extending up to the lower edge of the cabinet). Then you can sit on the bed and see to apply your make-up or comb your hair. ❖

**Editor’s Note:** I look forward to receiving lots more helpful hints and tips from all of you reading this newsletter. Sharing via the eGroup is great, but a large majority of our members do not participate there. This newsletter goes to every member.



**One Man's Life** by Peter Shaffer**WHAT GOES UP MUST COME DOWN**

After driving eight hours in a blinding snow storm, passing several accidents where cars and semi's had slid off the interstates, we arrived at Canaan Valley State Park in West Virginia. We decided to take the BigD and head to the mountains of our neighboring state, strap on a pair of snow skis and have some fun sliding down the mountain. About two feet of snow had recently fallen in the higher elevations, and big drifts were the norm.



Temperatures were forecast to go down to about 5 degrees above zero. The beauty of the snowfall, the lure of the scenery, and the chance to see our black Lab, Licorice, play in the deep snow, made the trip one we were looking forward to. An added bonus was the fact we were supposed to meet another Discovery couple, Dick and Vivian, there.

It was dusk when we arrived and we attempted to find a campground site that was cleared wide enough to fit our coach. Now as you can imagine, West Virginia has some hills . . . some very big hills. And, naturally, the campground is built on the hillsides. All of the internal campground roads are either uphill or downhill. With the roads all white with about 6" of hard packed snow, we had a bit of trepidation as we nosed down the first hill, wondering if we would be able to make it back up the other side. All went well, and we rounded the first bend in the road. Then the road went up sharply, and so did the Discovery. I was pleasantly surprised at how well she drove in the snow. Up we went, and not a wheel was spinning. This baby handled better than my Honda does in the snow! We were heading toward one campsite in particular that was reported to be the best spot in the campground – a space where we could see for miles and miles, see the ski slopes, and see the sunrises – a site I was secretly racing Dick and Vivian to before they had to turn back for home due to mechanical problems.

We found the site, but alas, it wasn't plowed clear. But there were several other sites accessible, so we stopped, left the engine running, set the parking brake and we got out to look around. We looked at several sites, did some measuring. We decided on the larger of the available ones and were just about to turn and walk back down to the

warm coach and get inside, when I heard a scream of terror. I turned and saw my wife running downhill, holding the door handle on the Discovery. Then it hit me, the BigD was accelerating away from me . . . backward! And Sharon was trying to stop it!

I did what any man would do in this situation – I started to run like the blazes. No, not away from my screaming wife, but toward her. I took about three steps when my feet went out from under me. My noggin was the first thing to hit the snow covered road, hard enough to see stars, and then I started to slide feet first downhill toward the sliding motor home and screaming wife. Sharon didn't scream much longer though. The motor home outpaced her ability to run and hold on, so she fell.

Well, now we were in a pickle. Our precious home-away-from-home was sliding toward some unknown fate. My wife was sprawled out in the middle of the snow covered road; I was flat on my back, sliding downhill. To top it all off, Licorice was chasing after me, thinking this was all a game! Some days it just doesn't pay to get up in the morning!

Somebody was looking out for us that evening. They say that "God looks out after children and fools." Any guess which one Sharon thinks I am right about now? The BigD took a hard turn to starboard, and went rear-end into a large snow bank.

The engine was still running when I climbed aboard and I was able to drive her out of the snow bank on a path that would take her back uphill. When we reached the spot where this all started, I saw the reason for the sudden departure of motor home and owners: the heat from the idling engine had melted the snow and turned the spot on the road to a very slick, icy area. This was the same spot where I stepped my last step before falling and seeing the Milky Way through closed eyelids. The BigD must have spotted the area also, because she balked at going uphill any more and came to a stop. The "I think I can, I think I can" attitude of the BigD suddenly changed to "no way, José." We were at a standstill. I couldn't get traction to go uphill, and if I took my foot off the brake pedal, even with the parking brake set, she would start to slide backward. Now what do I do?

During the conference with my better half, Sharon asked what I had on board that would chock the motor home from moving. That's it, why didn't I think of that, I had wheel chocks with me (duh)! I told her

where they were stored, and while I held the brake on, she went out and got them and installed them behind the front wheels, since the parking brake would lock the rear wheels.

We then called the state park personnel at the lodge and asked if they could send over someone with a bucket of crushed rock so we could get some traction and be on the move again. They said their gravel pile was at the other side of the park, and it was too bad outside to send someone all the way over there to obtain some. But they would be glad to send someone to the campground to help push. When I explained that my coach weighed somewhere around ten tons, the phone went silent for a moment. I can just imagine her look, and her mouth moving saying the words, "Ten tons?" Then she came back online and asked, "Just how big is your camper, and where did you say you were?"

While we waited for the gravel to arrive, we did the only thing we could: Sharon made a pot of delicious soup and with some homemade bread and we ate supper. We were finishing washing the dishes when the pickup arrived with the crushed rock, and I set out to shovel a good supply in my wheel tracks. With the gravel down, we were able to get the traction we needed and move the motor home uphill to our chosen site.

After all of this, you ask, was the skiing worth it? You bet, the skiing was first class that week. Did Licorice have fun in the deep snow? Yes, he plowed snow with his head down and tail up until he dropped from exhaustion. Did I enjoy beating Dick to the campground? Well, it was a hollow victory since they had to turn back, but as they say, "any port in the storm." Did we get to see any sunrises? We slept in that next morning recovering from the previous evening's excitement, but subsequent mornings were spectacular! Did we learn anything from this experience? (This is my father's favorite question.) Yes, Dad, I learned that Sharon may be good at a lot of things, but she isn't any good at stopping a 21,000 pound motor home from its reaction to the effects of gravity on a snowy road! ❖

*Peter and Sharon Shaffer live in Kentucky, are doting grandparents, and travel extensively through the U.S. Peter is a retired civil engineer and until recently was assisting FEMA as a mediator for those affected by this past year's hurricanes.*

**Why belong to DOAI?** 1) Clout of many in getting problems solved with Fleetwood; 2) Information, information, information; and 3) Sharing good times with other Discovery owners. –Elsie Sikes

**On-the-Road Safety Tips for RV'ers** by Mark Polk

Forty thousand people in the United States die each year on the road! RV'ers spend a great deal of time on the open road. I want to offer a few safety tips to keep in mind when traveling by RV. Most will apply to automobiles, too.



1. Avoid driving or pulling your RV during bad weather and high winds. Because of the size and mass of RV's, it can be extremely dangerous to travel during periods of high winds.
2. Limit your driving time to five or six hours a day (300 to 350 miles). Not only will you be more alert, but you will arrive at the campground with plenty of daylight left to get set up and settled in before it's dark outside. **Never drive when you're tired!**
3. Drive defensively! Stay alert and monitor what is going on around you at all times. Use your mirrors. For increased visibility, purchase some convex mirrors that you can stick on your side view mirrors. These mirrors are inexpensive and are available in auto parts stores. They come in different sizes and will improve your visibility a great deal, especially along the sides of the RV and in blind spots.
4. Eventually you will have to pass another vehicle in your RV. It's not difficult to pass, but with a large RV, it requires more space than the average car. Make sure you have plenty of room and use your turn signals to change lanes. Accelerate until you are past the other vehicle and you can see both of their headlights in your mirror. Signal again to return to the other lane and pull back in. Maintain your speed ahead of the vehicle you just passed.

5. Always leave plenty of room between you and the vehicle in front of you. RV's are much heavier than your automobile and require a longer braking distance to come to a stop. This alone will prevent accidents, especially during emergency braking. Driving at a safe speed also lowers your braking distance. Always use a supplemental braking system on the vehicle you are towing as well.
6. Complete a pre-trip checklist every day before hitting the road. Simple checks like checking your tires, lights, hitch work, and other items all contribute to a safer trip. You can make your own checklist or check out our second edition *Checklists for RV'ers* e-book. Either way, the important thing is that you follow it.
7. Cell phones are nice to have for emergencies. Do not use a cell phone when you are driving. If you must make a call, have someone who is not driving do it for you.
8. **Never drink and drive!**
9. These are the ten deadliest days of the year to drive. Mark them on your calendar and stay put on these dates. One more day at the campground or getting to your destination one day later can't hurt you, and driving on these dates could do much worse:

☞ July 4	☞ July 3	☞ December 23
☞ August 3	☞ January 1	☞ August 6
☞ August 4	☞ August 12	☞ July 2
	☞ September 2	❖

Mark Polk is a published author in the RV industry and produces RV training videos and DVDs on how to use and maintain your RV. The goal of his company, RV Education 101, is to make all your RV'ing experiences enjoyable, fun, and most importantly, **safe**. Sign up for your free RV Education 101 monthly e-newsletter at [rveducation101.com/email/](http://rveducation101.com/email/)

**Welcome, New Members!**

These intelligent Discovery owners have joined DOAI since our last newsletter. We welcome them to our ranks!

David/Helen Altstadt, Discovery Bay CA  
 Ivan/Sheila Backes, Columbus NE  
 Wilmer Bates, Orange Park FL  
 Royce/Sue Brookmole, Granbury TX  
 Toni Calzone, Rockville MD  
 Jim/Marilyn Casey, Visalia CA  
 Ronald Cooke, The Villages FL  
 Janice Delancey, Pataskala OH  
 John/Nancy Delmatoff, Murrieta CA  
 Gary/Rita Denning, Lenexa KS  
 Clyde/Jerrie Dennis, Ragley LA  
 Peter DiFonzo, Willoughby Hills OH  
 Ronald Doak, Westbrook ME  
 Ben/Iola Ennis, Denham Springs LA  
 Michael Fazio, Davie FL

James/Linda Gower, Merritt Island FL  
 Arlie/Barbara Graybeal, Lenoir NC  
 Gary/Felix Hallberg, McAllen TX  
 Wayne/Deborah Hannah, Fayetteville GA  
 Allen Headley, Wind Ridge PA  
 Ennis Herrmann, Bowling Green KY  
 Tanya Holley/Beth Morgan, Greensboro NC  
 Roy/Sheila Hunsaker, Livingston TX  
 Raymond Jachowski, Bartow FL  
 Graham/Treana Kerr, Camano Island WA  
 Thomas/Sandra Komadina, Wentzville MO  
 Paul Korman, Daytona Beach FL  
 John/Jan Kovach, Colorado Sprgs CO  
 Thomas/Edna Lackey, Wharton TX  
 Calvin Lakey, Wichita Falls TX  
 Mark/Cathy List, Sioux Falls SD  
 Anthony/Sherry Mancuso, Vanderbilt PA  
 Evelyn Martin, Homestead FL  
 Leroy/Shirley McBain, Van Alstyne TX  
 Michael McLeod, Gloucester MA

Michael Melvin, St James City FL  
 Jack/Nim Myton, Calgary AB  
 Ellwood Nelson/Sonia Wilson, Vineland NJ  
 William Picard, Preston CT  
 R. Lee/Beverly Querry, Phoenix AZ  
 David Rankin, Tampa FL  
 Richard/Melba Rhodes, Boerne TX  
 Jim/Joyce Sage, Lincoln City OR  
 Everett Salisbury, Zephyrhills FL  
 Michael Silvestro, Merritt Island FL  
 Halley/Lovetta Simpson, San Antonio TX  
 James/Diane Smith, Scottsdale AZ  
 James/Whitney Steiner, San Ramon CA  
 Bob/Barbara Stillwell, Angel Fire NM  
 Jerry/Barbara TeVrucht, Tullahoma TN  
 Wayne/Carol Thorpe, Zeeland MI  
 John Troupe, Waterloo IA  
 Ira Watson, Las Vegas NV  
 Gregory Wiggins, Lyons GA  
 Austin Zappala, St Augustine FL ❖

**From Then to Now, Part One**

*A brief look back at our beginnings, tracing the road we have traveled to the present.*

Once upon a time, in a galaxy far, far away....oops, wrong story! OK, once upon a time, not so long ago, there lived a man and his wife. They decided that hitting the road in a recreational vehicle was the only way to spend their time together. So they shopped around, and shopped around, and eventually they purchased a Fleetwood Discovery motor home.

Their new home on wheels had all the amenities for the easy life ... television, refrigerator, air conditioning, room, lots of storage space, and a good, strong engine to take them just about anywhere they wished to visit.

Now as the time went by, the man and his wife saw other Discovery motor homes and thought to themselves, "It would be fun to get together with other Discovery owners...we'd have so much in common right from the start, and we'd make new friends."

And so it was born...the idea to form Discovery Owners Association, Inc.

The man (of course you know it's Jim Devine) and his wife (yes, the sweet Dorothy Devine) set about contacting every Discovery owner they could track, suggesting that everyone gather together and form a club. This involved the cooperation of many people and much time and effort, and yes, donations of funds. But the idea appealed to many Discovery owners, and so the dye was cast.

The inaugural club rally was held November 2-4, 1998, in Perris, California, at Camper Resorts of America. The registration fee was \$10 and the site fee was \$21 a day. The food was plentiful...no one went away hungry!

From the beginning Fleetwood and Freightliner were important participants in and supporters of our organization. At that first rally Fleetwood provided a tech trainer, Jim Pourroy, who is familiar to many of us. Ron Anders from Freightliner was there to pass on lots of helpful information. Jim Yearian from Cummins was also present with helpful information for all. Beadry RV was visible throughout the rally, and there were new 1999 D's for participants to walk through.

Here are a few photos from that happy event. Do you recognize anyone? Does it bring back memories? More next time as we travel that road once again. ❖



Here are some of the 58 coaches attending the rally!



The food was plentiful and oh, so delicious. Beadry RV popped for a dinner one evening.



People enjoyed making new friends and talking about their D's.



Lorrie Petersen was the first newsletter editor.



Games were played and everyone got into the "fun" groove.



Beadry RV presented gifts to Jim and Dorothy to be given to all rally attendees.



**SOUTHEAST REGION 2006 RALLY  
 TRI-CHAPTER FRIENDSHIP FESTIVAL**

THURSDAY, JANUARY 26 - TUESDAY, JANUARY 31, 2006

Lazydays RallyPark, off Interstate 4, Exit 10, Seffner, FL

Early Arrival: Wednesday, Jan. 25 – Late Departure: Wednesday, Feb. 1

Pilot's Last Name \_\_\_\_\_ First Name (MI) \_\_\_\_\_

Co-Pilot's Last Name \_\_\_\_\_ First Name (MI) \_\_\_\_\_

Street Address \_\_\_\_\_

City, State, ZIP \_\_\_\_\_

DOAI # \_\_\_\_\_ Cell Phone \_\_\_\_\_ E-mail \_\_\_\_\_

Emergency Contact \_\_\_\_\_

Emergency Telephone \_\_\_\_\_

Handicap Parking (circle one)    Yes    No    **Must post handicap tag**

Cost for **five nights' and six days' camping** with all amenities and more:

\$210.00 per coach with two adults ..... \$ \_\_\_\_\_

\$172.00 per coach with one adult ..... \$ \_\_\_\_\_

\$48.00 each additional adult ..... \$ \_\_\_\_\_

\$28.00 each child ..... \$ \_\_\_\_\_

\$T/B/D each additional day ..... \$ \_\_\_\_\_

**Make check payable to Lazydays RallyPark ..... \$ \_\_\_\_\_**

**Mail check and complete registration form to:**

Lazydays RallyPark  
 6210 County Road 579  
 Seffner, FL 33584-3004

Telephone 800.905.6657  
 E-mail [rallypark@lazydays.com](mailto:rallypark@lazydays.com)

**Register early** with Lazydays to assure yourself of a site. Please use this registration form to avoid confusion. **MAKE YOURSELF A COPY.** If you arrive early, plan to have your own party at your site ... the recreation hall is reserved on January 25 by another group.

**Driving instructions** – call immediately – 800.626.7800



No show, no refund  
*This form has been approved by Lazydays RallyPark*

## Sale Page for Members

This feature is available to any DOAI member, free of charge. Simply send the information to the editor, preferably via e-mail. Include full information, **and send a photo, too.** Items for sale will run in two issues of this newsletter.



**1999 Discovery 37V:** One owner, 42,000 miles, no smoke, no pets, it's a "10"! All the options including washer/dryer, convection/microwave oven, side-by-side refrigerator with icemaker, two ACs, two TVs, satellite dish, VCR, back-up camera, new tires, aluminum wheels, wheel covers, new batteries, leather pilot and co-pilot seats, couch, and recliner. Plum color. Recently serviced and ready to go. \$88,000. Contact Victor Kania at 505.896.0242, or [k.lout14@aol.com](mailto:k.lout14@aol.com).



**1998 Discovery 36T:** 275 hp Cummins/6 speed Allison, two A/C's, slide, washer/ dryer, awnings, 41,000 miles. \$70,000. Contact Mary McGrory at 623.875.7215 or [mmcgrory-phx@worldnet.att.net](mailto:mmcgrory-phx@worldnet.att.net).



**1998 Discovery 36T:** Well maintained and serviced, 65,000 miles, burgundy. Factory loaded plus built-in computer desk with recliner, washer/dryer, side-by-side

refrigerator with icemaker, full height built-in pantry plus other customized storage, 10-disk CD player with surround sound, CB radio, auto satellite dish, spare tire, and new batteries. Awnings all around with window vents, coach-mounted 7,500 lb. hitch. \$75,000 firm. Contact Ron Hyslop at 239.304.0731 or [saron@prodigy.net](mailto:saron@prodigy.net).



**2000 Discovery 37V:** All the options including 275 hp Cummins/6 speed Allison, privacy sun screens all around plus matching wheel covers,

"Magic" vents on both holding tanks, custom-made oak computer desk with storage cabinet, Euro recliner leather chair and ottoman, free-standing table with chairs, enlarged kitchen drawers, pantry fitted with wooden pull-out cabinet interior, wooden-fronted drawers under sofa on full suspension gliders, additional storage cabinets added along dining area wall, side-by-side refrigerator with icemaker, and more! Additional photos and

information at [www.urbancampers.com](http://www.urbancampers.com) or contact John and Barbara Nelson at 731.298.6369 or 850.454.7858. Unit located near Pensacola, Florida.

**1999 Discovery 37V:** One owner, non-smoking, extra sharp. Onan propane generator, side-by-side refrigerator with icemaker, washer/dryer, microwave/convection oven plus gas oven, two slides, booth, couch and leather recliner. Mauve color. 58,000 miles and ready to go. \$83,000. Contact Allan Gustafson, 155 E. Rodeo Rd., Casa Grande, AZ 85222; 520.836.5534; [aagust96@wmconnect.com](mailto:aagust96@wmconnect.com).



**2001 Discovery 38D:** Caterpillar 330 diesel pusher, two slides, Allison 6 speed transmission, Onan diesel generator, 7.5 (motion) track vision, washer/dryer, AC, side-

by-side refrigerator/freezer with icemaker, Corian countertops, convection/microwave, central vacuum, and much more. Transferable extended warranty 70,000 or 05/08, mileage 42,000, like new, one owner 05/01, always kept in heated garage, non-smoker, no pets. \$115,000. Contact Dick Wilson at 828.389.9035; cell 239.281.0068; [wilsonohiostate@msn.com](mailto:wilsonohiostate@msn.com).

**1998 Discovery 36T:** Well maintained, 61,000 miles, non-smoking, no pets. Includes all new tires at 45,000 miles, mounted spare tire, external tire rack, generator, convection/microwave oven, washer/dryer, side-by-side refrigerator with icemaker, two AC units, back-up camera, awning, steer safe added, two leather couches, leather pilot and co-pilot chairs. Plum interior. Coupled propane tanks, built-in closet with clothes hamper. Purge water tank system. \$78,000 or best offer. For more information contact Bernie Abbott at 561.615.4509; cell 561.236.5811; [blabbott11@aol.com](mailto:blabbott11@aol.com).

**Bicycle Rack:** Supports two bikes, purchased from Camping World, selling for \$25.



**Hitch Extension:** Purchased from Camping World, selling for \$25. Contact Franklin Howell at [fdhowell@worldnet.att.net](mailto:fdhowell@worldnet.att.net).

**Wanted to Buy:** Coach- or toad-mounted tow bar for 1997 Discovery 36. Contact Blaine Petersen at 928.284.2696; [blainelori@aol.com](mailto:blainelori@aol.com). ❖



National DOAI Rally 2005 – Dutch Treat

August 9-13, 2005

York EXPO Center, York, Pennsylvania



REGISTRATION FORM

Please PRINT or TYPE all information as you want it to appear on your name tag.

Pilot's Last Name \_\_\_\_\_ First Name \_\_\_\_\_

Co-Pilot's Last Name \_\_\_\_\_ First Name \_\_\_\_\_

Street \_\_\_\_\_ City, State, ZIP+4 Code \_\_\_\_\_

DOAI # \_\_\_\_\_ Local Chapter \_\_\_\_\_ First National Rally? \_\_\_\_\_

Home Phone \_\_\_\_\_ Cell Phone \_\_\_\_\_ E-Mail \_\_\_\_\_

Guest(s) Name, City, State \_\_\_\_\_

Emergency Contact \_\_\_\_\_ Emergency Telephone \_\_\_\_\_

DOAI USE ONLY
Site # \_\_\_\_\_

Check all applicable:

- Need handicap parking, DOAI officer, Seminar presenter, Vendor, Chapter officer

Costs (includes 4 nights' camping with water and 30 amps, 2 dinners, 4 breakfasts, 4 evenings' entertainment):

- \$187 per coach with two adults (mailed by July 25, 2005)
\$197 per coach with two adults (mailed after July 25 or on site at rally)
\$132 per coach with one adult (mailed by July 25, 2005)
\$142 per coach with one adult (mailed after July 25 or on site at rally)
\$60 each additional adult per coach x
\$18 per night early arrival x
\$20 DOAI membership (if not already a DOAI member)

MAKE CHECK PAYABLE TO: DISCOVERY OWNERS ASSN., INC. Check Enclosed \$

MAIL CHECK AND REGISTRATION FORM TO: Marian Giordano, Registrar, 3277 Hemlock Farms, Lords Valley, PA 18428-9114

QUESTIONS? Call Marian (tollfree 1-888-857-7048) or e-mail (mbg3037@msn.com)

EARLY REGISTRATION BY MAIL ONLY – MUST BE MAILED BY JULY 25, 2005

Activities: I/we are interested in participating in the following events:

- 55 Alive, Book Exchange, Craft/White Elephant, Harley Davidson Tour, Red Hat Social, Golf, Parade of Homes, Pfaltzgraff Tour

VOLUNTEERS NEEDED!

- Parking, Seminars, Golf Helper, Workshop Helper, Registration, Door Prizes, Entertainment, Vendor Helper, Reporter, 50/50 Game, Breakfast Helper, Merchandise Sales, Photographer, Clean-up Crew, First Aid, Where Needed

COPY FORM FOR YOUR RECORDS – NO SHOW, NO REFUND

Editor's Ramblings

by Nina Lee Soltwedel

They say, "Never let them see you sweat." That means, when the pressure is on, don't indicate that it's getting to you. When you're nervous, you make others nervous.



So, even though this issue is late, I ain't sweating...much! In the first place, it hasn't been hot enough for that, and in the second place...well, there is no second place, I guess.

I do, however, apologize for the lateness of this issue. I thought I'd have everything in hand while on the road, but just couldn't pull it all together. I missed my nice, big, RAM-fat computer at home.

I thank each of you for your patience. When a newsletter comes but four times a year, it can seem like a very long time between issues. I hope you enjoy this one.

Have you noticed the color? The board decided to go the next step (the first was the extra color you saw in the previous issue) and have a full-color cover. It was fun working with the manufacturers' logos and the colors.

Sincere Thanks

We owe a big THANK YOU to Lazydays RV Center in Seffner, Florida. Did you know? Lazydays pays the first year's membership dues to DOAI for every new Discovery sold!

That's quite a commitment in support of DOAI, and we truly appreciate it. Of course, we hope that those who receive the first year's membership will continue when that year is up. To that end, we keep endeavoring to provide you with a lot of helpful information, and a little fun along the way.

Here's a challenge to those of you who may be near a Fleetwood Discovery dealer: Speak with the general manager, and ask if they would be interested in perhaps following Lazydays' lead in paying for the first year's dues for new Discovery purchasers. Nothing ventured, nothing gained.

More Thanks

The photos of the Orange Blossom Romp in this issue were graciously provided by Fay and Bobby Williams. The photos from the first ever Discovery rally were generously provided by Judy and Loren Petersen. I thank them, and I thank those chapter members who sent in photos for this issue. I just wish I could have used all of them!

Further thanks go to Fleetwood and its staff. They will be providing helpful articles in future issues. Don't miss the first one in this issue on page 15.

In Closing

I hope to see many of you in the coming months as we all travel in our wonderful motor homes...and for sure at the upcoming national rally in York. It'll be a doozy! ❖

DISCOVERY OWNERS ASSOCIATION, INC. MEMBERSHIP APPLICATION

Welcome to an organization open to all owners of Discovery motor homes by Fleetwood RV. DOAI is an organization intended to foster social opportunities and information exchange among members.

Dues are \$20.00 for the first year\*; \$16.00 for one year renewal; \$45.00 for three years, or \$75.00 for five years. \*New members pay an additional \$4.00 one-time administrative fee.

PLEASE...PAYABLE IN U.S. FUNDS ONLY!

Questions? Call 888.594.6818

Mail the form below with your check payable to Discovery Owners Association, Inc. to:

PORTIA WILLIAMS, MEMBERSHIP DIRECTOR
P. O. BOX 95
ST. GEORGE, UT 84771-0095

Pilot Last Name \_\_\_\_\_ First \_\_\_\_\_ Co-Pilot \_\_\_\_\_

Address \_\_\_\_\_

City, State, ZIP+4 Code \_\_\_\_\_

Home Telephone \_\_\_\_\_ Cell Telephone \_\_\_\_\_

Discovery Year \_\_\_\_\_ Length and Model \_\_\_\_\_ E-Mail Address \_\_\_\_\_

Is this your first RV? Yes \_\_\_\_\_ No \_\_\_\_\_ Are you a full-time or part-time RV'er? \_\_\_\_\_

Check enclosed for \$ \_\_\_\_\_ representing (check one): [ ] One year [ ] Three years [ ] Five years

D.O.A.I. thanks these fine manufacturers for providing financial assistance in the production of this newsletter



**THE LEADER AT EVERY TURN™**



**Discovery** Owners Association, Inc.

Portia Williams, Membership Director  
P. O. Box 95  
St. George, UT 84771-0095

Pre-Sorted  
FIRST CLASS MAIL  
U.S. Postage Paid  
Boulder, CO  
Permit No. 94

ADDRESS SERVICE REQUESTED